

Ai-HB 075A / Ai-HB 100A

Ai-HB 125A / Ai-HB 150A

Ai-HB 175A / Ai-HB 200A

# Ai-HB G2 Series Battery

## Quick Installation Guide



Android



iOS



# 1 General Information

This quick installation guide does not replace the description in the user manual.

The contents of this guide may be updated or revised due to product development. The information in this guide is subject to change without notice. The latest version of this document and the manual for installation, commissioning, configuration and decommissioning are to be found in PDF format at [www.solplanet.net](http://www.solplanet.net).

## 2 Safety

### 2.1 Intended use

The product is a battery system for residential and works with the solar hybrid inverters. It is a high voltage Li-ion battery storage system that has its own control unit. It can be operated in on-grid, off-grid and backup modes with all the compatible inverters.

The product is suitable for indoor and outdoor use. Outdoor use as long as temperature range is fulfilled between  $-20^{\circ}\text{C}$ ~ $50^{\circ}\text{C}$ .

The product must only be operated with the inverters which are claimed by AISWEI. The inverters must be compatible with this product.

The battery system must only be used as stationary equipment.

Alterations to the product are not allowed unless the written permission of AISWEI is achieved. Unauthorized alterations will void the guarantee and warranty claims. AISWEI will not be held liable for any damage caused by such illegal changes.

The product is not suitable for supplying life-sustaining medical devices. Please ensure that no personal injury would lead due to the power outage of the battery system.

The product must only be used in countries for which it is approved or released by AISWEI and the grid operator.

Use this product only in accordance with the information provided in this documentation and with the locally applicable standards and directives. Any other application may cause personal injury or property damage.

The type label must remain permanently attached to the product.

This document does not replace any regional, state, provincial, federal or national laws, regulations or standards that apply to the installation, electrical safety and use of the product.

## 2.2 Important safety instructions

The product has been designed and tested in accordance with international safety requirements. To prevent personal injury and property damage and to ensure long-term operation of the product, read this section carefully and observe all safety information at all times.

### DANGER

#### **Danger to life due to high voltages of the battery!**

When the battery system connected to the inverter, and the circuit breaker is ON, the batteries will generate a high DC voltage which will be present in the DC cable and live components.

- Do not touch non-insulated parts or cables.
- Do not touch the DC conductors.
- Do not touch any energized part of the product.
- Do not open the product.
- All work on the product must only be carried out by qualified personnel who have read and fully understood all safety information contained in this document.
- Disconnect the product from voltage sources and ensure it cannot be reconnected before working on the product.
- Wear suitable personal protective equipment, in accordance with local regulations, when working on the product.

### WARNING

#### **Danger to life due to electric shock from destruction of measurement devices due to overvoltage!**

Overvoltage can damage a measurement device and result in voltage being present in the enclosure of the measurement device. Touching the live enclosure of the measuring device results in death or lethal injuries due to electric shock.

- Only use measuring devices with a higher voltage range than the system battery voltage.

## WARNING

### **Risk of injury due to weight of product!**

Injuries may result if the product is lifted incorrectly or dropped while being transported or mounted.

- Lift and transport the product carefully.
- Wear suitable personal protective equipment, in accordance with local regulations, when working on the product.

## NOTICE

### **Damage to the battery system due to electrostatic discharge!**

Internal components of the battery system can be irreparably damaged by electrostatic discharge.

- Ground yourself before touching any component.

## NOTICE

### **Damage to the BCU due to particles and water!**

Particles such as dust and sand can damage the BCU and impair its functionality.

- Only open the BCU top cover when the humidity is within the permitted range of the product and the environment is free of dust and sand.

## 2.3 Symbols on the label

---



**Beware of a danger zone!**

This symbol indicates that the product must be additionally grounded if additional grounding or equipotential bonding is required at the installation site.

---



**Beware of high voltage and operating current!**

The inverter operates at high voltage and current. Work on the inverter must only be carried out by skilled and authorized electricians.

---



**Beware of explosion!**

The battery is an electro chemical, and there is an explosion risk in extreme cases. Please keep away of it when the danger occurs.

---



**Beware of danger to children!**

The battery must be inaccessible to children.

---



**Beware Flammable**

Keep the battery system away from open flames or ignition sources. of danger with flam!

---



**WEEE designation**

Do not dispose of the product together with the household waste but in accordance with the disposal regulations for electronic waste applicable at the installation site.

---



**CE marking**

The product complies with the requirements of the applicable EU directives.

---



**Certification mark**

The product has been tested by TÜV and obtained the quality certification mark.

---



**RCM Mark**

The product complies with the requirements of the applicable Australian standards.

---



**The battery is recyclable**

The battery can be recycled by a professional recycling organization, please refer to the relevant local regulations.

---



**Observe the documentation**

Observe all documentation supplied with the product.

---

### 3 System Wiring Diagram

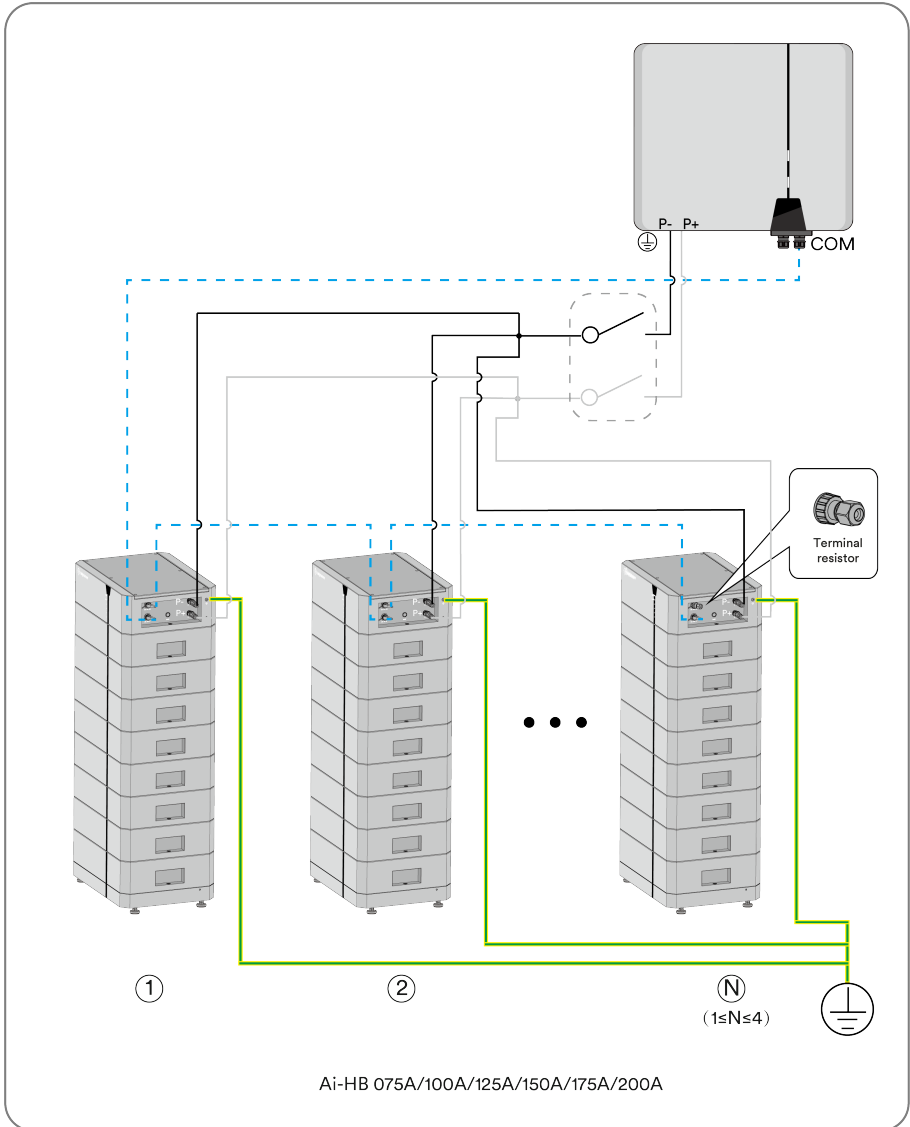

## 4 EU Declaration of Conformity

Within the scope of the EU directives:

-Electromagnetic compatibility directive 2014/30/EU

(L 96/79-106, March 29, 2014)(EMC)

-Low voltage directive 2014/35/EU (L 96/357-374, March 29, 2014)(LVD)

Restriction of the use of certain hazardous substances 2011/65/EU

(L 174/88, June 8, 2011) and 2015/863/EU (L 137/10, March 31,2015) (RoHS)

AISWEI New Energy Technology (Yangzhong) Co., Ltd confirms herewith that the products described in this document are in compliance with the fundamental requirements and other relevant provisions of the above mentioned directives. The entire EU Declaration of Conformity can be found at [www.solplanet.net](http://www.solplanet.net).



## 5 Overview

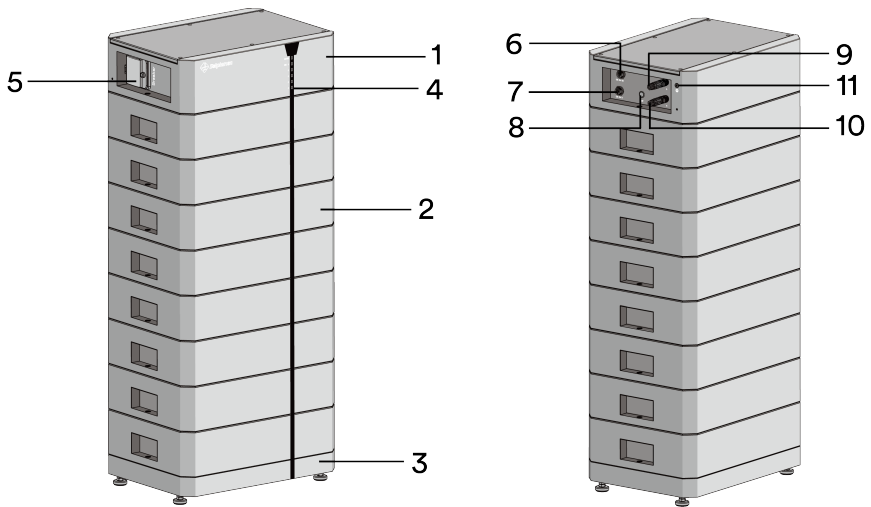

Object	Description
1	Battery control unit (BCU)
2	Battery Module
3	Base
4	LED indicator
5	Circuit breaker

6	Link port out
7	Link port in
8	On/Off
9	P-
10	P+
11	Grounding

## 6 Scope of Delivery

### 6.1 BCU and Base Package

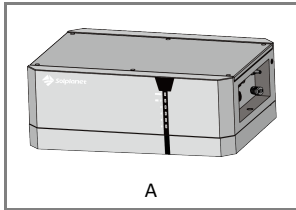

A

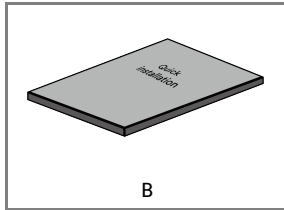

B

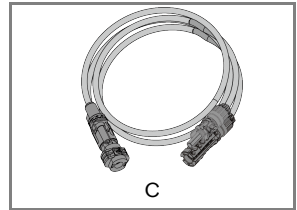

C

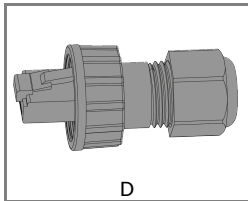

D

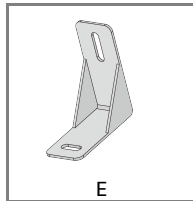

E

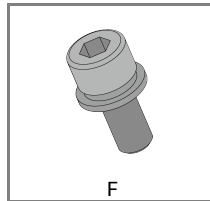

F

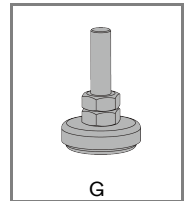

G

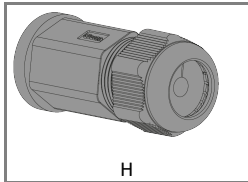

H

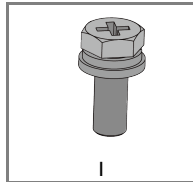

I

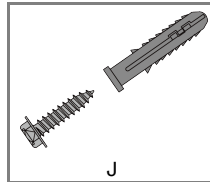

J

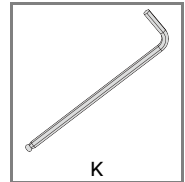

K

Object	Description	Quantity
A	BCU and Base	1
B	Quick installation guide	1
C	Positive cable and negative cable	1
D	Terminating resistor	1
E	L-bracket	2
F	M5X12 Screw	2

G	Foot (At the bottom of the packaging)	4
H	Cable gland	1
I	Hexagon screw (M6 X 16)	1
J	Expansion Anchor Bolt (8 X 40)	2
K	Hex Key S=4	1

## 6.2 Battery Module Package

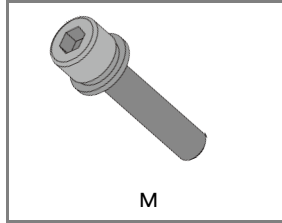
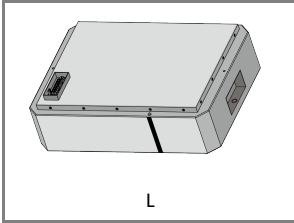

Object	Description	Quantity
L	Battery Module	1
M	M5x25 Screw	2

## 7 Mounting Environment

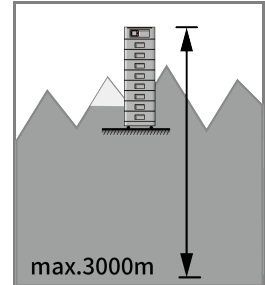
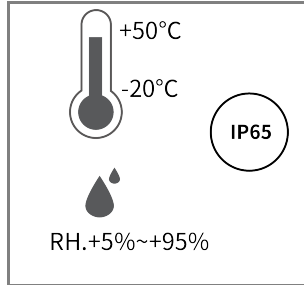
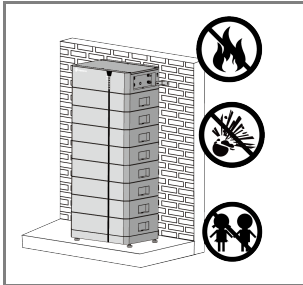

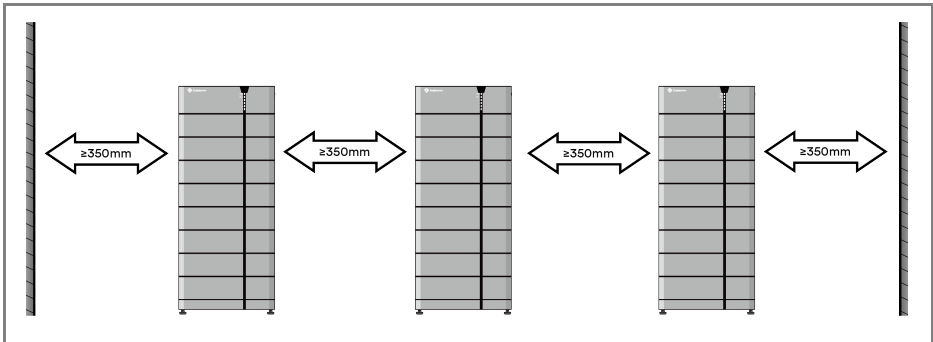
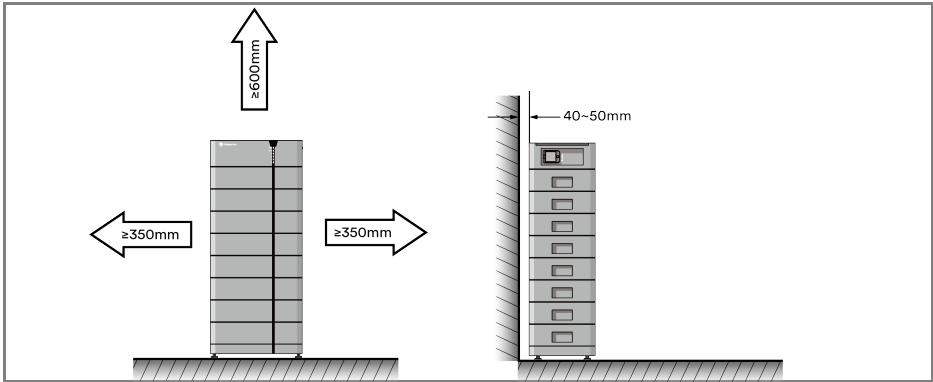
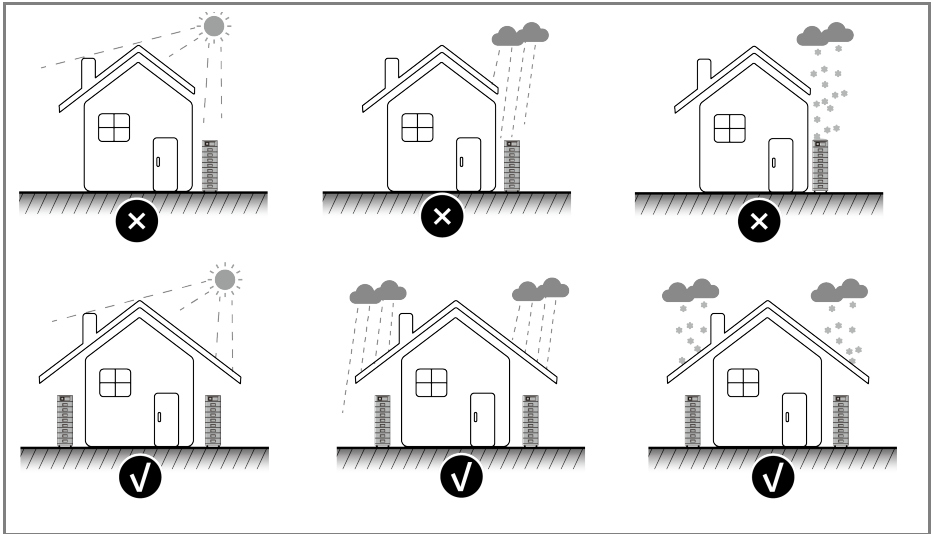

## 8 DIMENSIONS

Unit:mm

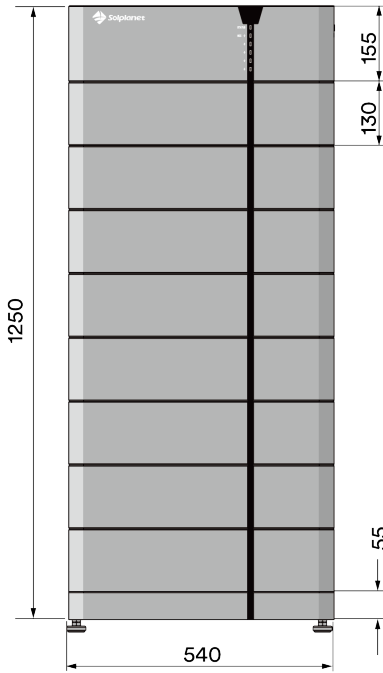

## 9 Mounting

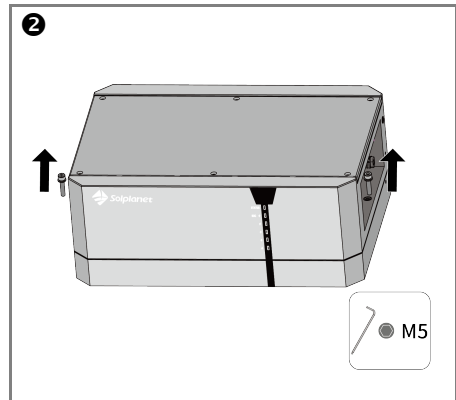
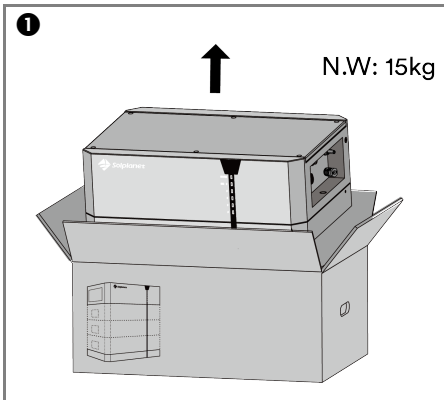

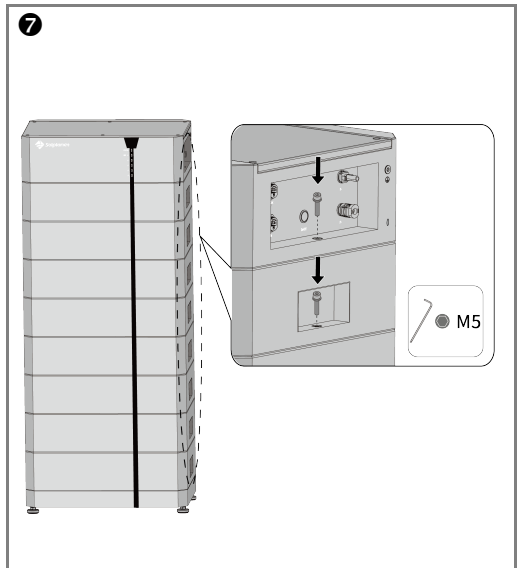
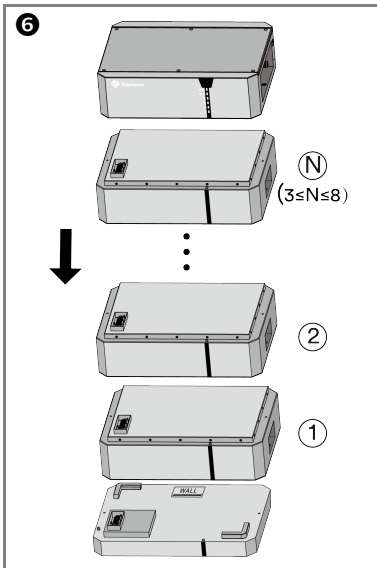
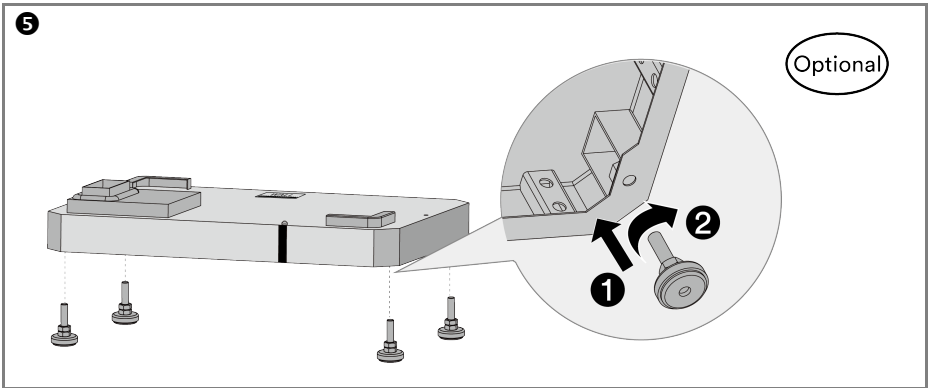
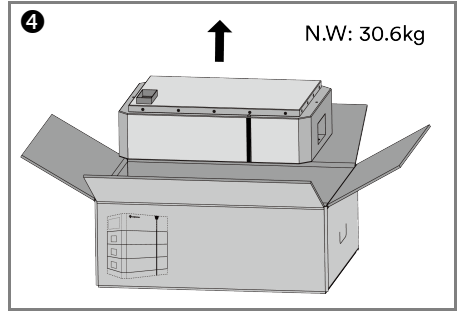
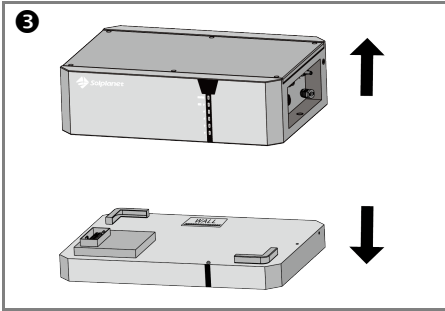

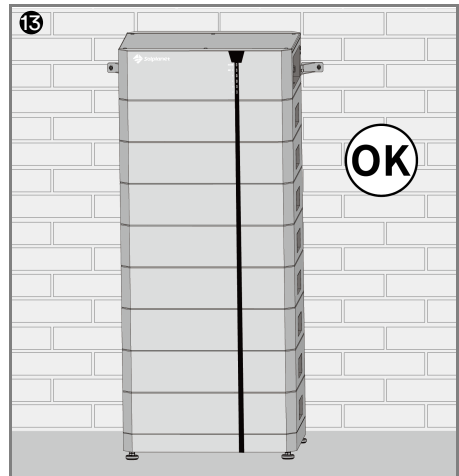
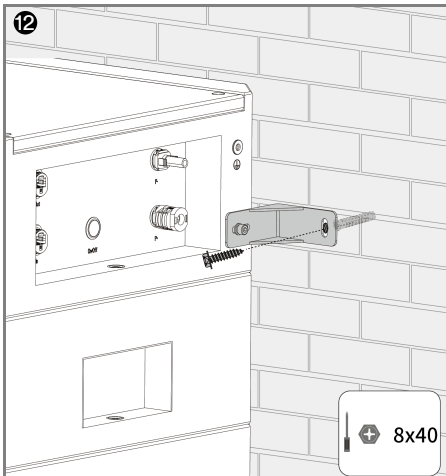
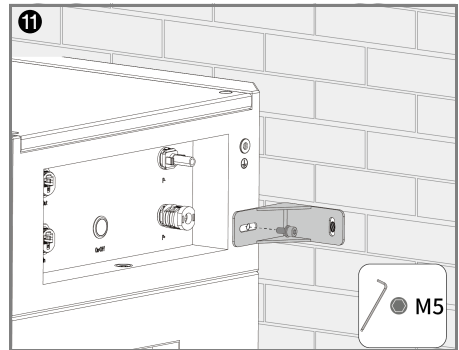
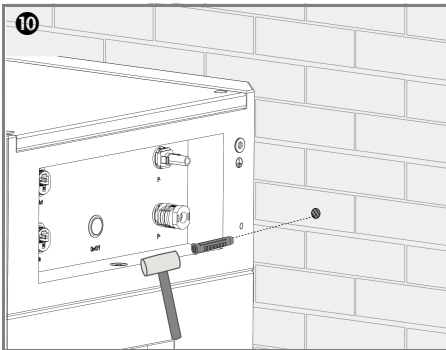
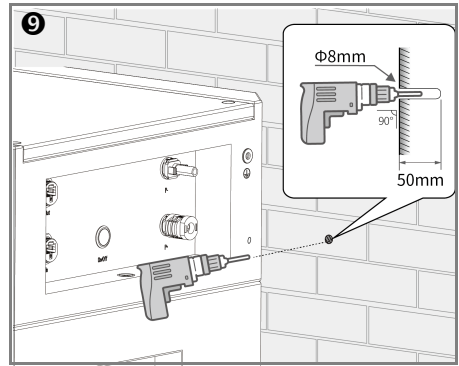
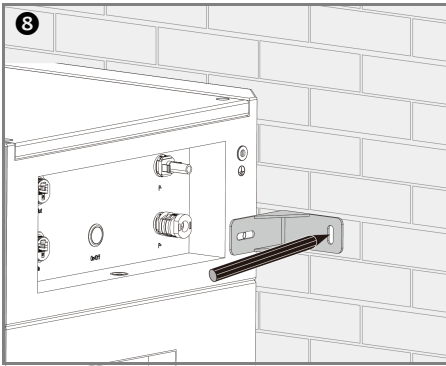

## 10 Second Protective Grounding

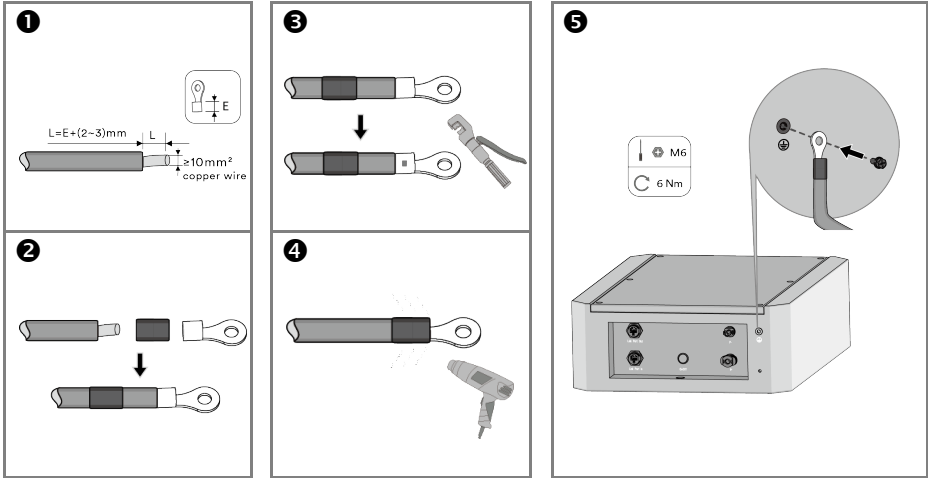

## 11 Battery Connection

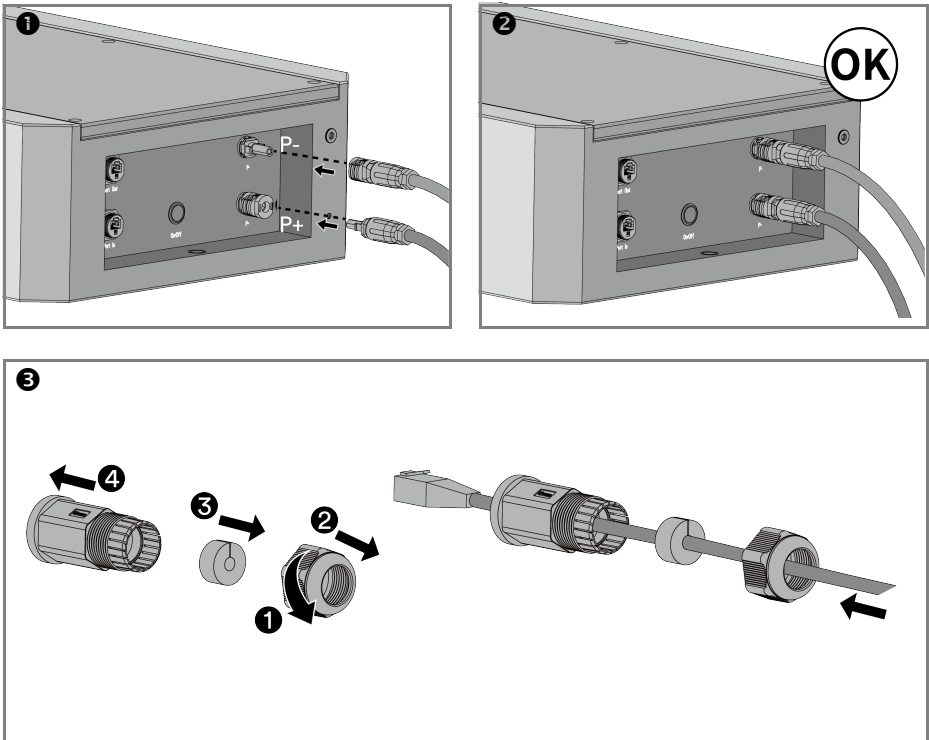

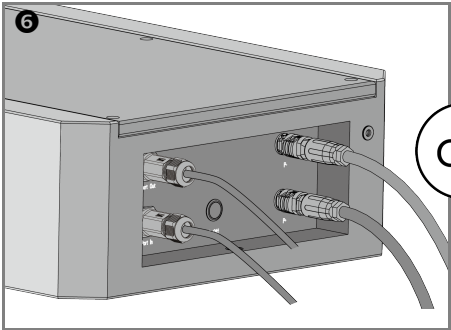
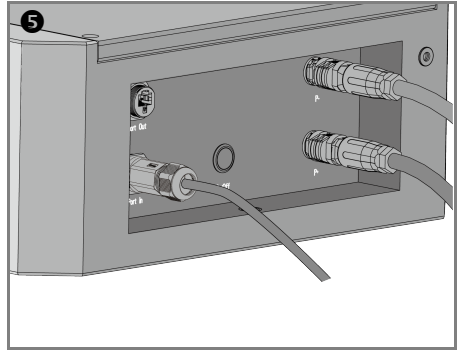
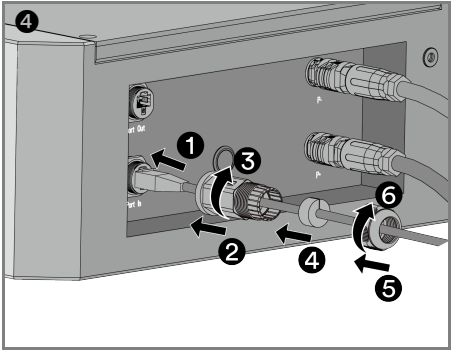

OR

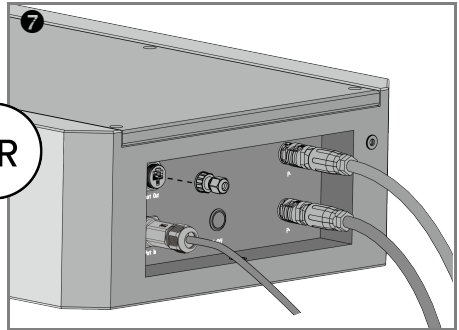

## 12 Contact

Please contact our Service Department if you have any technical questions about our products.

The following information is needed to provide necessary assistance:

- Battery model
- Battery control unit and module series number
- Fault code
- Installation location

EMEA

Service email: [service.EMEA@solplanet.net](mailto:service.EMEA@solplanet.net)

APAC

Service email: [service.APAC@solplanet.net](mailto:service.APAC@solplanet.net)

LATAM

Service email: [service.LATAM@solplanet.net](mailto:service.LATAM@solplanet.net)

Aiswei Greater China

Service email: [service.china@aiswei-tech.com](mailto:service.china@aiswei-tech.com)

Hotline: +86 400 801 9996

Taiwan

Service email: [service.taiwan@aiswei-tech.com](mailto:service.taiwan@aiswei-tech.com)

Hotline: +886 809089212

<https://solplanet.net/contact-us>

Scan QR code:



Android

Scan QR code:



iOS



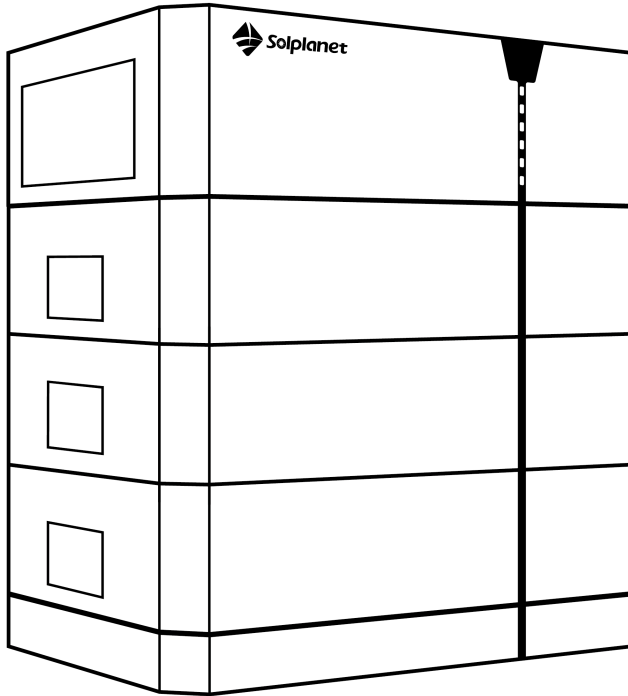

**Solar for Everybody**



AISWEI Technology CO., Ltd

Zur Verfügung gestellt von: [www.photovoltaikshop.eu](http://www.photovoltaikshop.eu)