

Ai-HB 075A/Ai-HB 100A

Ai-HB 125A/Ai-HB 150A

Ai-HB 175A/Ai-HB 200A

# Ai-HB G2 Series Battery

## User Manual

## Contents

1	General information .....	3
1.1	About this document.....	3
1.2	Product validity.....	3
1.3	Target group.....	3
1.4	Symbols .....	4
2	Safety.....	5
2.1	Intended use .....	5
2.2	Important safety instructions.....	5
2.3	Symbols on the label.....	7
3	Unpacking and storage.....	8
3.1	Scope of delivery .....	8
3.2	Product storage .....	9
4	Battery system overview .....	10
4.1	Product description.....	10
4.2	Dimensions.....	11
4.3	LED indicator .....	11
4.4	Interfaces and functions .....	13
5	Mounting .....	14
5.1	Requirements for mounting.....	14
5.2	Mounting.....	17
6	Electrical connection.....	22
6.1	Overview of the connection area.....	22
6.2	Connecting the grounding conductor.....	22
6.3	Connecting the power cable and network cable .....	23
6.4	Parallel system connection diagram .....	27
7	Commissioning and operating .....	29
7.1	Inspection before commissioning .....	29
7.2	Commissioning procedure.....	29
8	Decommissioning the product .....	30
9	Technical data .....	31
10	Troubleshooting .....	32
11	Maintenance.....	33
12	Recycling and disposal .....	34
13	EU declaration of conformity .....	34
14	Service and warranty.....	34
15	Contact .....	35

# 1 General information

## 1.1 About this document

This document describes the mounting, installation, commissioning, configuration, operation, troubleshooting and decommissioning of the Ai-HB battery energy storage system (BESS).

You will find the latest version of this document and further information on the BESS in PDF format at [www.solplanet.net](http://www.solplanet.net).

It is recommended that this document be readily accessible at all times.

## 1.2 Product validity

This document is valid for the following models:

- Ai-HB 075A
- Ai-HB 100A
- Ai-HB 125A
- Ai-HB 150A
- Ai-HB 175A
- Ai-HB 200A

## 1.3 Target group

This document is intended for qualified persons who must perform the tasks exactly as described in this user manual.

All installation work must be performed by appropriately trained and qualified persons.

Qualified persons must possess the following skills:

- Knowledge of how batteries work and are operated.
- Knowledge of how an inverter works and is operated.
- Training in how to deal with the dangers and risks associated with installing, repairing and using electrical devices and batteries and installations.
- Training in the installation and commissioning of electrical devices.
- Knowledge of all applicable laws, standards and directives.
- Knowledge of and compliance with this document and all safety information.

Not adhering to the prescribed instructions may potentially void the manufacturer's warranty. If in doubt please contact the local Solplanet service team.

## 1.4 Symbols

### **DANGER**

Indicates a hazardous situation which, if not avoided, will result in death or serious injury.

### **WARNING**

Indicates a hazardous situation which, if not avoided, could result in death or serious injury.

### **CAUTION**

Indicates a hazardous situation which, if not avoided, could result in minor or moderate injury.

### **NOTICE**

Indicates a situation which, if not avoided, can result in property damage.



Information that is important for a specific topic or goal, however not related to safety.

## 2 Safety

### 2.1 Intended use

The Ai-HB is a BESS is for both residential and commercial applications and operates with Solplanet hybrid inverters.

- It is a high voltage Li-ion BESS controlled via a battery control unit (BCU).
- It can be operated in on-grid, off-grid and backup modes with all officially compatible Solplanet inverters.
- The product is suitable for indoor and outdoor use.
- The product must only be used as stationary equipment.
- Alterations to the product are not allowed unless authorised in writing by Solplanet.
- Unauthorised alterations will void the guarantee and warranty claims. Solplanet will not be held liable for any damage caused by such unauthorised alterations.
- The product is not suitable for supplying power to life-sustaining medical devices.
- Please ensure that no personal injury would lead due to the power outage of the battery system.
- The product must only be used in countries for which it is approved for by Solplanet.
- Use this product only in accordance with the information provided in this documentation and with the locally applicable standards and directives. Any other application may cause personal injury or property damage.
- The type label must remain permanently attached to the product.
- This document does not replace any regional, state, provincial, federal or national laws, regulations or standards that apply to the installation, electrical safety and use of the product.

### 2.2 Important safety instructions

The product has been designed and tested in accordance with international safety requirements.

To prevent personal injury and property damage and to ensure long-term operation of the product, read this section carefully and observe all safety information at all times.

#### **DANGER**

Danger to life due to high voltages of the battery !

When the battery system connected to the inverter, and the circuit breaker is ON, the batteries will generate a high DC voltage which will be present in the DC cable and live components.

- Do not touch non-insulated parts or cables.
- Do not touch the DC conductors.
- Do not touch any live components of the product.
- Do not open the product.
- All work on the product must only be carried out by qualified personnel who have read and fully understood all safety information contained in this document.
- Disconnect the product from voltage sources and ensure it cannot be reconnected before working on the product.
- Wear suitable personal protective equipment, in accordance with local regulations, when working on the product.

## **DANGER**

Danger to life due to electric shock where surge protection is not used!

If there is no surge protection, a voltage surge can be conducted into the building and to other connected devices in the same system through power cables, network cables or other types of cable. Touching live parts and cables may result in death or lethal injury due to electric shock.

- Ensure all devices in the same system and the inverter are integrated within an existing surge protection systems/devices.
- Refer to local installation regulations to determine the requirements for the installation of surge protection devices.

## **WARNING**

Danger to life due to electric shock from destruction of measurement devices due to overvoltage!

Overvoltage can damage a measurement device and result in voltage being present in the enclosure of the measurement device. Touching the live enclosure of the measuring device results in death or lethal injuries due to electric shock.

- Only use measuring devices with a higher voltage range than the system battery voltage

## **WARNING**

Risk of injury due to weight of product!

Injuries may result if the product is lifted incorrectly or dropped while being transported or mounted.

- Lift and transport the product carefully.
- Wear suitable personal protective equipment, in accordance with local regulations, when working on the product.

## **NOTICE**

Damage to the battery system due to electrostatic discharge!

Internal components of the battery system can be irreparably damaged by electrostatic discharge.

- Ground yourself before touching any component.

## **NOTICE**

Damage to the BCU due to particles and water!

Particles such as dust and sand can damage the BCU and impair its functionality.

- Only open the BCU cover when the humidity is within the permitted range of the product and the environment is free of dust and sand.

## 2.3 Symbols on the label

---



**Beware of a danger zone**  
This symbol indicates that the product must be additionally grounded if additional grounding or equipotential bonding is required at the installation site.

---



**Beware of high voltage and operating current!**  
The product operates at a high voltage and current. Work on the product must only be carried out by skilled and authorized personnel.

---



**Beware of explosion!**  
The battery is an electro-chemical device, and there is an explosion risk in extreme cases. Please keep away of it when the danger occurs.

---



**Beware of danger to children!**  
The battery must be inaccessible to children.

---



**Flammable**  
Keep the battery system away from open flames or ignition sources.

---



**WEEE Designation**  
Do not dispose of the product together with household waste. Dispose the product in accordance with local disposal regulations for electronic waste.

---



**CE marking**  
The product complies with the requirements of the applicable EU directives.

---



**Certification mark**  
The product has been tested by TÜV and obtained the quality certification mark.

---



**CE marking**  
The product complies with the requirements of the applicable EU directives.

---



**The battery is recyclable**  
The battery can be recycled by a professional recycling organization, please refer to the relevant local regulations.

---



**Observe the documentation**  
Read and understand all documentation supplied with the product.

---

## 3 Unpacking and storage

### 3.1 Scope of delivery

Check the scope of delivery for completeness and any visible external damage. Contact your distributor if the scope of delivery is incomplete or damaged.

BCU and Base Package:

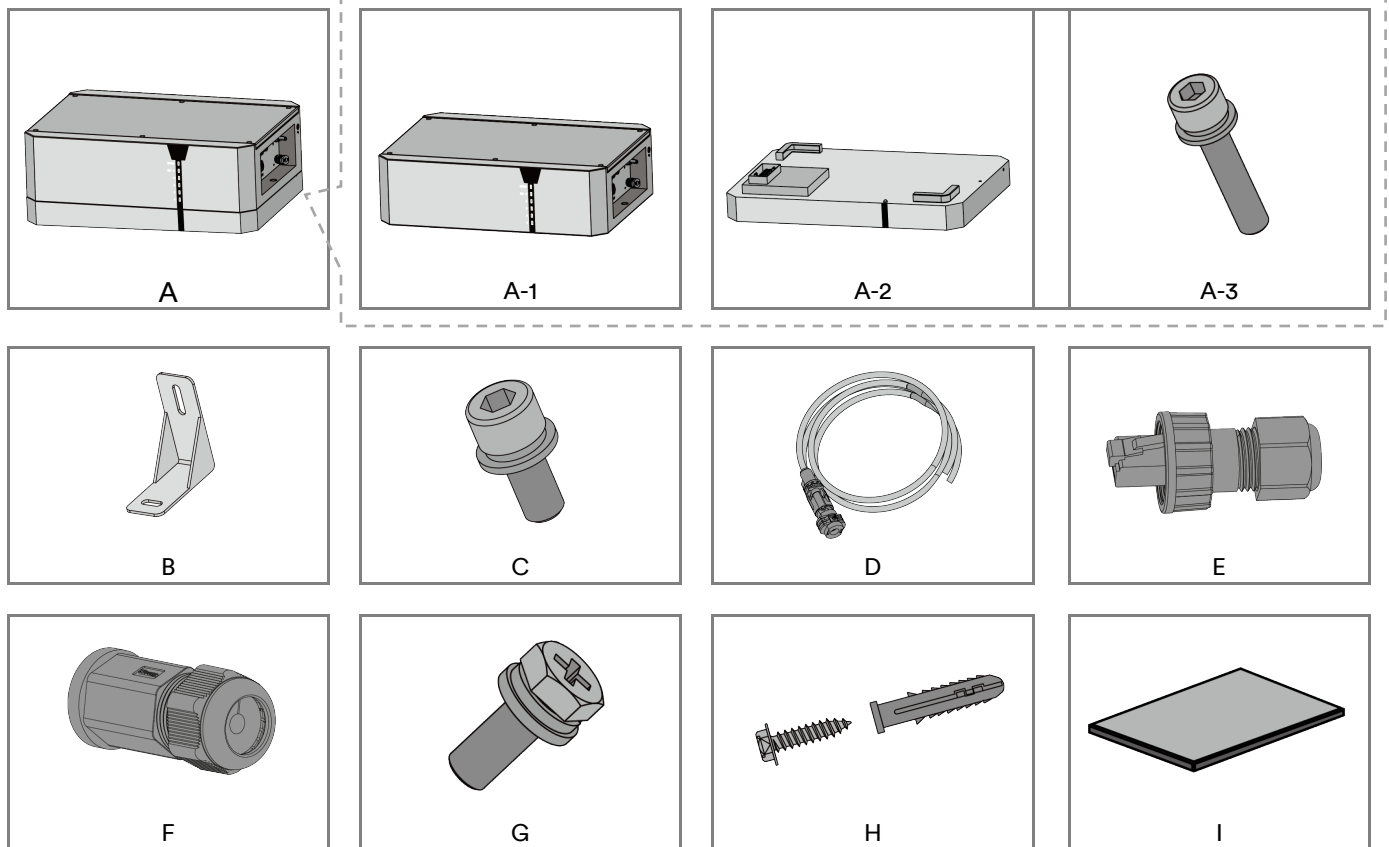

Battery Module Package:

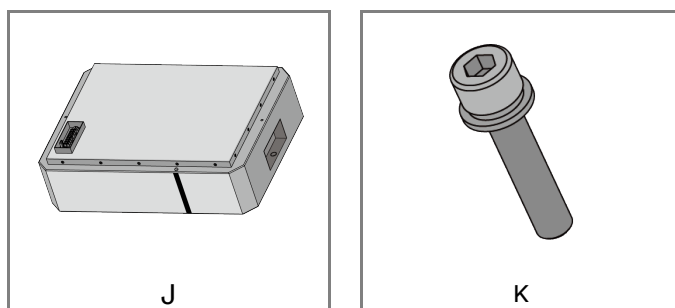

Object	Description	Quantity
A	BCU and Base	1
A-1	BCU	1
A-2	Base	1
A-3	M5×25 Hexagon socket head screw	2
B	L-bracket	2

C	M5×12 Hexagon socket head screw	2
D	Positive cable and negative cable (1.5m, 6mm <sup>2</sup> )	1
E	Terminating resistor	1
F	Cable gland	1
G	M6×16 Hexagon screw	1
H	M8×40 Expansion Anchor Bolt	2
I	Documents	1
J	Battery Module	1
K	M5×25 Hexagon socket head screw	2

## 3.2 Product storage

Suitable storage is required if the equipment is not installed immediately:

- Store the battery in the original packing case.
- The storage temperature must be between -20°C to +45°C, and the storage relative humidity must be between 5% and 95%, non-condensing.
- The storage SOC: 25%~50%. Re-charge the battery every 6 months, to ensure no over-discharge of the battery occurs.
- The packing with the equipment shall not be tilted or inverted.
- Place the equipment in a cool place away from direct sunlight.
- Keep the equipment away from flammable, explosive, and corrosive materials.
- Keep the equipment away from rain.
- The product must be fully inspected and tested by authorised personnel before it can be put into operation, if it has been stored for three or more months.

## 4 Battery system overview

### 4.1 Product description

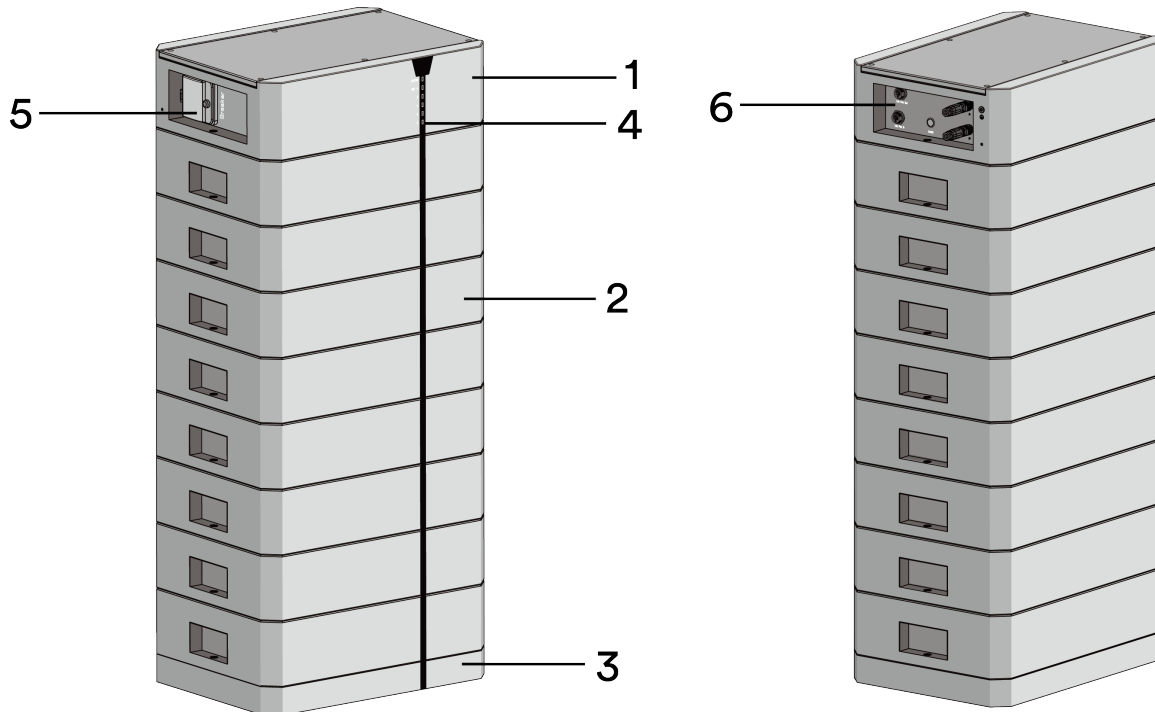
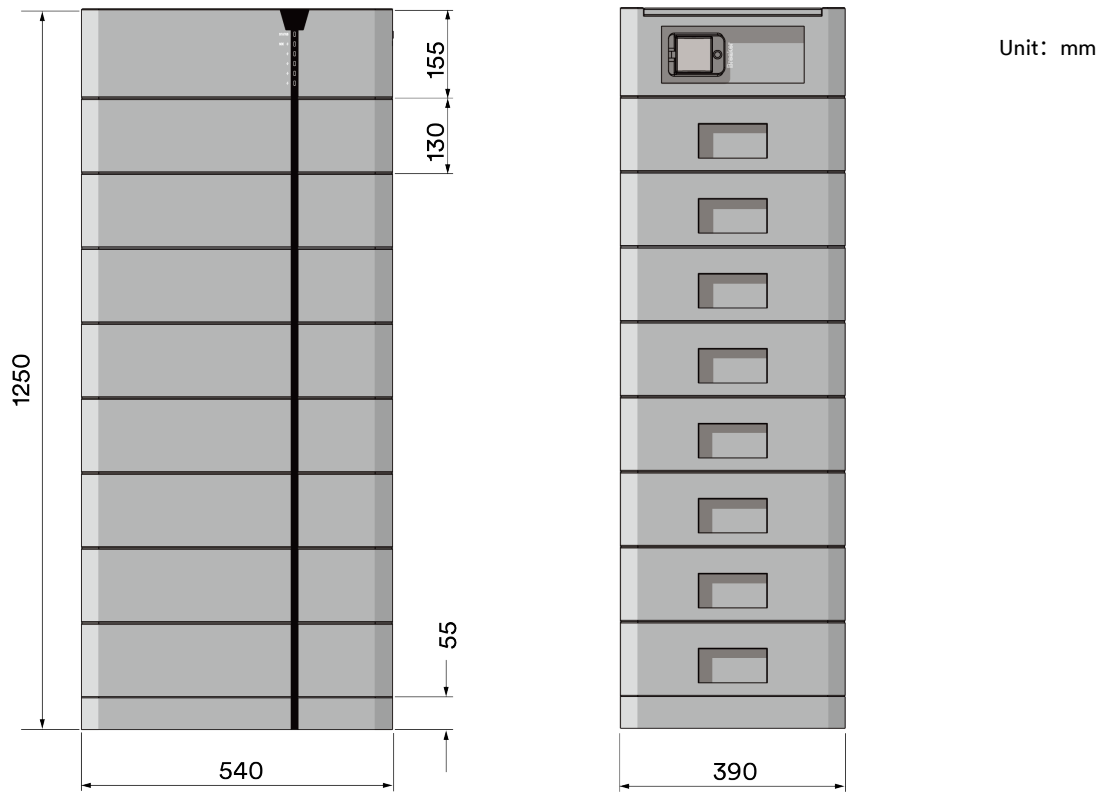

Figure shown here is for reference only. The actual product received may differ!

Object	Name	Description
1	BCU	Battery control unit.
2	Battery Module	Ai-HB G2 battery module.
3	Base	The battery base which is used to support the battery.
4	LED indicator	Indicate the current operating state of the battery.
5	Circuit breaker	Disconnect the high voltage from battery module to BCU.
6	Interface Panel	The interface panel containing the ON/OFF button, DC connectors and the “Link Port In” which is used to connect the BCU to the connected battery module.

## 4.2 Dimensions



## 4.3 LED indicator

The LED's on the BCU indicates the status of the BESS.



LED status definitions:

- Solid On: LED is permanently illuminated.
- Off: LED is off (is not illuminated).
- Blinking: LED illuminates for 1 second and turns off for 1 second.
- Pulsing: LED illuminates for 1.5 seconds and turns off for 5 seconds.

Function	LED	Description
Status	Blinking	Indicates an alarm.
	Solid ON	BCU is power on, and the battery is waiting to turn on.
	Off	Normal state.
	Solid ON	Indicates a fault.
SOC	ON	SOC:80%~100%
	ON	

	● ON	
	● ON	
	● ON	
SOC	● OFF	SOC:60%~80%
	● ON	
	● ON	
	● ON	
	● ON	
SOC	● OFF	SOC:40%~60%
	● OFF	
	● ON	
	● ON	
	● ON	
SOC	● OFF	SOC:20%~40%
	● OFF	
	● OFF	
	● ON	
	● ON	
SOC	● OFF	SOC:0%~20%
	● OFF	
	● OFF	
	● OFF	
	● ON	



There are five LEDs to indicate the State of Charge (SOC) of the battery and the different status of the LEDs indicates the different working state of the battery.

- Solid on (all bright LEDs according to SOC) indicated discharging state.
- Blinking on (only top bright LED according to SOC) indicated Charging state.
- Pulsing on (all bright LEDs according to SOC) indicate standby state.

## 4.4 Interfaces and functions

The product is equipped with the following interfaces and functions:

### Communication (CAN) Interface - “Link Port”

The “Link Port” is an RJ45 port used for connecting the BCU to an inverter. The product can communicate with the inverter through the CAN interfaces. The CAN interfaces can also be used for the parallel operation of the products.

### System startup

Turn on the circuit breaker. When the status indicator turns yellow, press the ON/OFF button for at least 3s, all lights will turn on from bottom to top, BESS is in working mode, and the device can be charged and discharged normally.

### System sleep

Press the ON/OFF button for at least 5s. Make sure that both the SOC indicator and the status indicator of the BCU are off.

### System shut down

Turn off the circuit breaker. Make sure that both the SOC indicator and the status indicator of the BCU are off.

## 5 Mounting

### 5.1 Requirements for mounting

#### 5.1.1 Requirements for Installation Location

#### **DANGER**

Danger to life due to fire or explosion !

Despite careful construction, electrical devices can cause fires. This can result in death or serious injury.

- Do not mount the product in areas containing highly flammable materials or gases.
- Do not mount the inverter in areas where there is a risk of explosion.
- A solid support surface must be available (e.g. concrete or masonry).
- The mounting location must be inaccessible to children.
- The installation location must be suitable for the weight and dimensions of the BESS.
- Keep away from conductive (metal) dust.
- Keep away from water sources, heat sources and inflammable and explosive articles.
- The installation location must not be close to fire.
- The product should be mounted such that the LED indicators can be read without difficulty.
- The circuit breaker of the BESS must always be freely accessible.
- The altitude of the installation location should be less than 3000 m.
- The operating temperature should be between  $-20^{\circ}\text{C}$  ~  $+50^{\circ}\text{C}$ .
- The ambient humidity should be between 5-95%.
- The mounting location must not be exposed to direct solar irradiation. If the product is exposed to direct solar irradiation, the exterior components may age prematurely and overheating might occur. When becoming too hot, the BESS reduces its power output to avoid overheating, and will reduce its lifetime also.

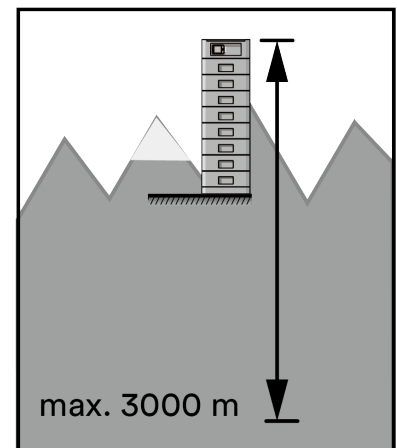
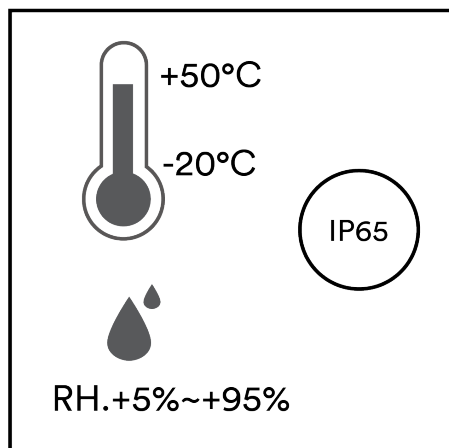
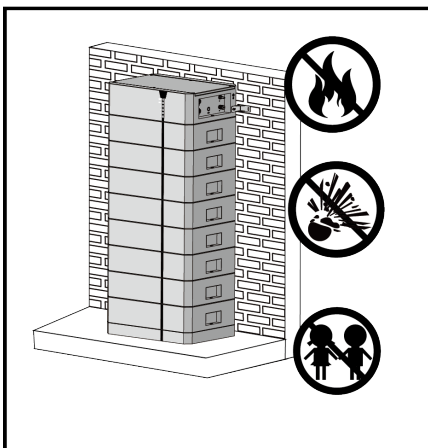

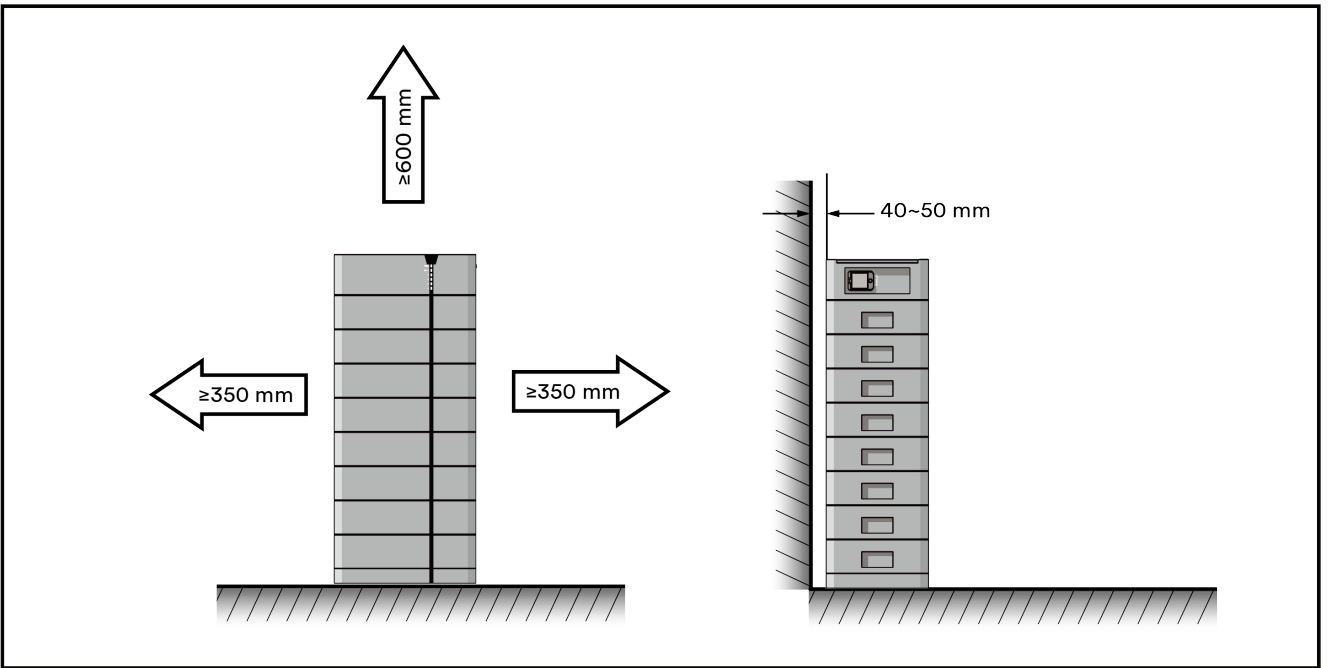
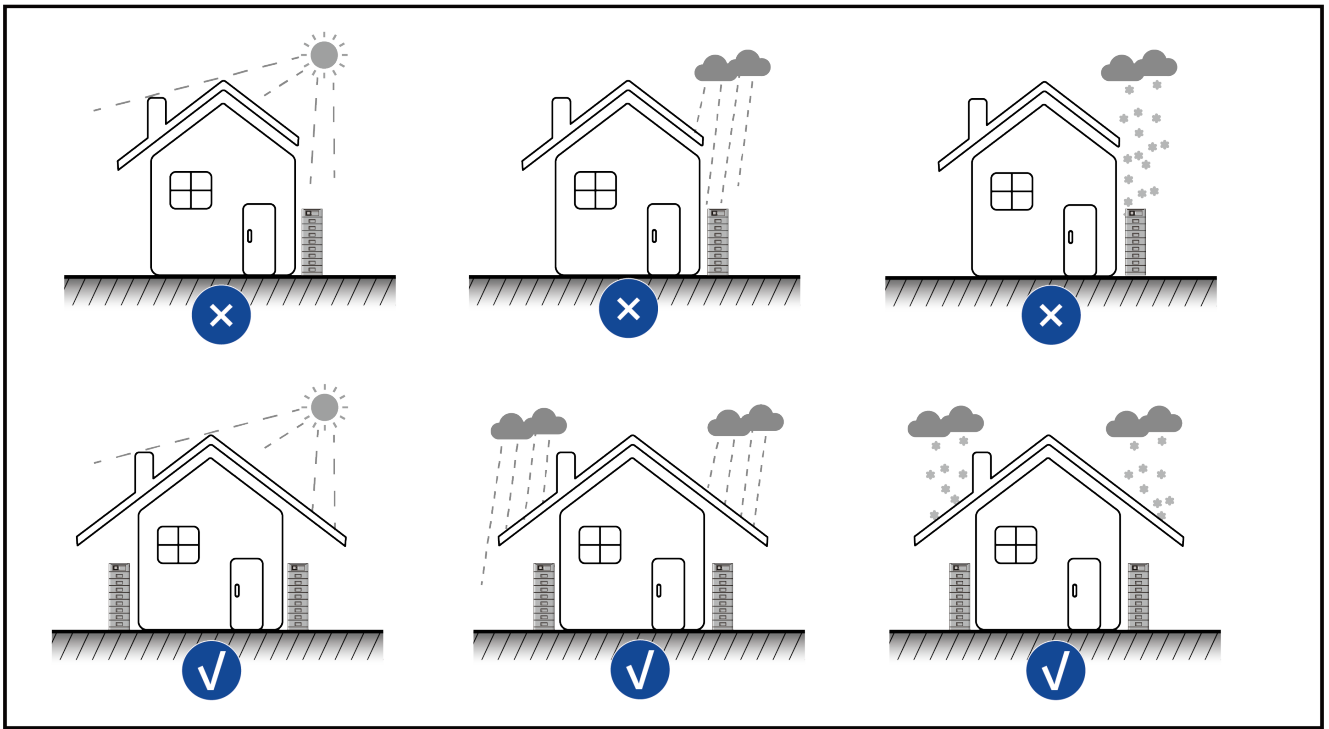

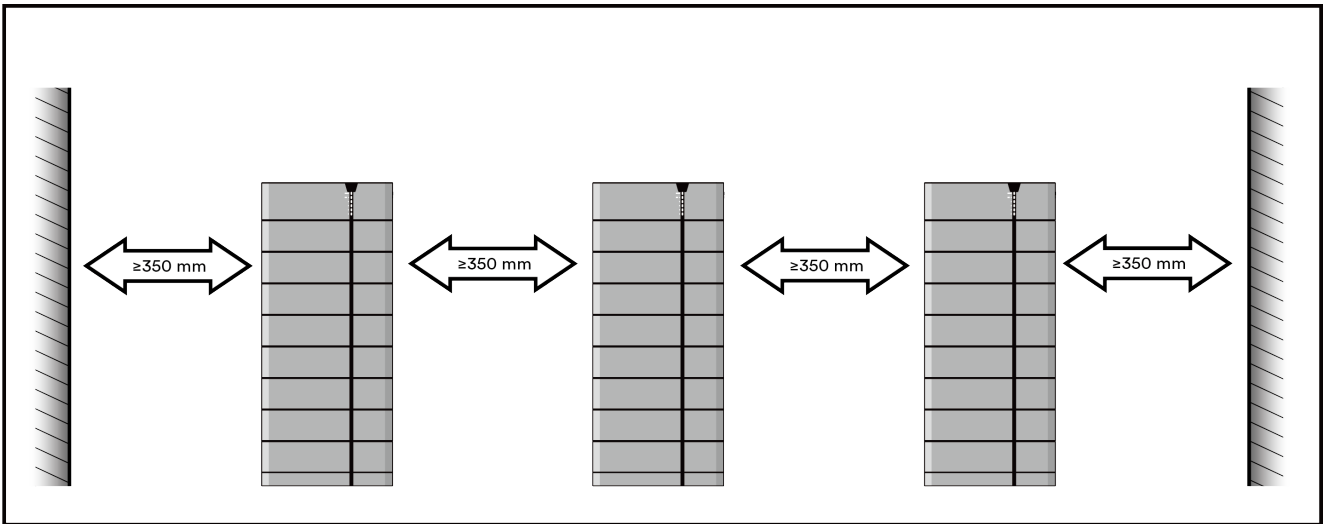

### 5.1.2 Tools

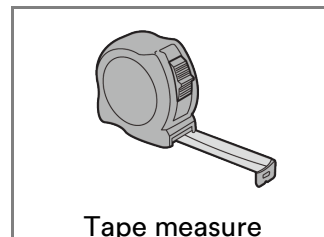
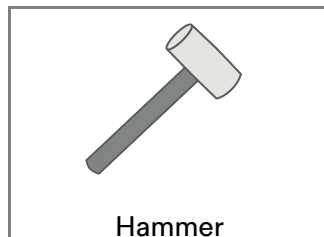
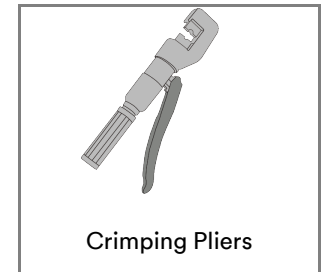
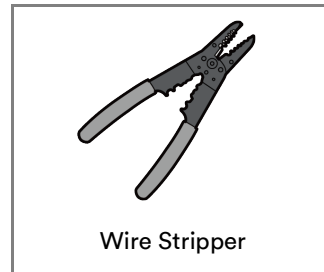
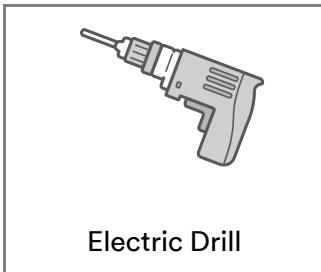
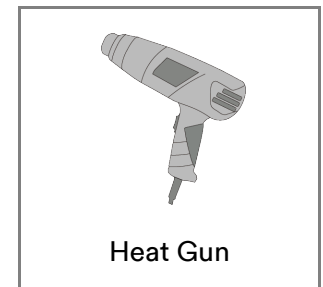
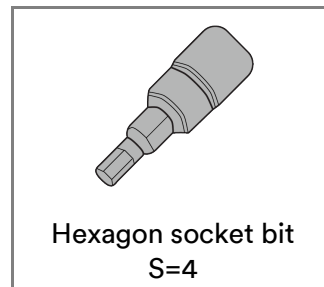
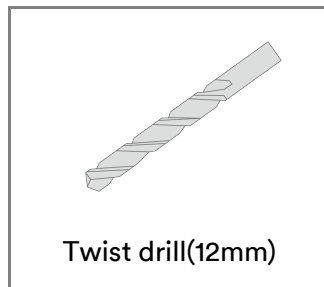
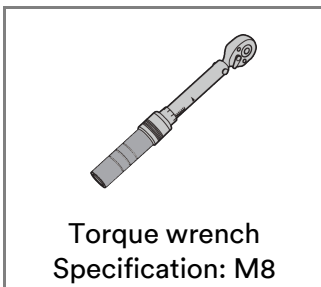
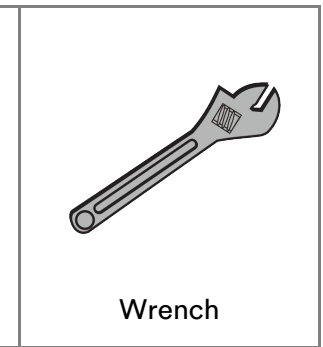
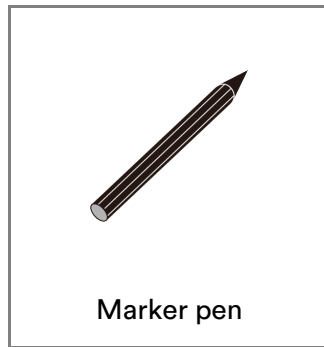

### 5.1.3 Safety gear

Wear the following safety gear when working on the BESS. Adhere to local occupational health and safety standards.

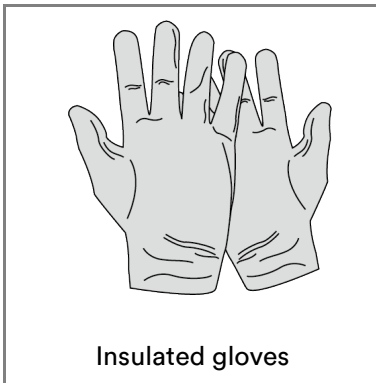

### 5.1.4 Additionally required installation material

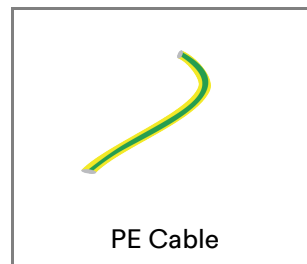
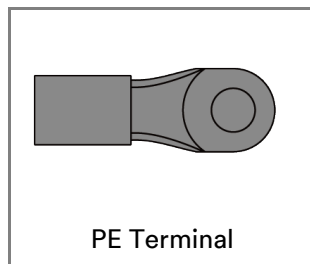
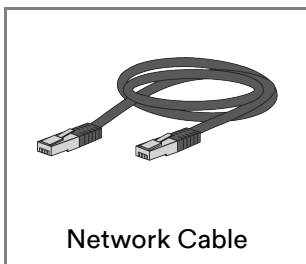

## 5.2 Mounting

### **DANGER**

Danger to life due to high voltages of the battery!

When the battery system connected to the inverter, and the circuit breaker is ON, the batteries will generate a high DC voltage which will be present in the DC cable and live components.

- Do not touch non-insulated parts or cables.
- Do not touch the DC conductors.
- Do not touch any live components of the product.
- Do not open the product.
- All work on the product must only be carried out by qualified personnel who have read and fully understood all safety information contained in this document.
- Disconnect the product from voltage sources and ensure it cannot be reconnected before working on the product.
- Wear suitable personal protective equipment, in accordance with local regulations, when working on the product.

### **WARNING**

Risk of injury due to weight of product!

Injuries may result if the product is lifted incorrectly or dropped while being transported or mounted.

- Lift and transport the product carefully.
- Wear suitable personal protective equipment, in accordance with local regulations, when working on the product.

**Step 1:** Remove the BCU and the base from the package and then separate the BCU and the base by removing the two screws(M5x25) that hold are holding them together.

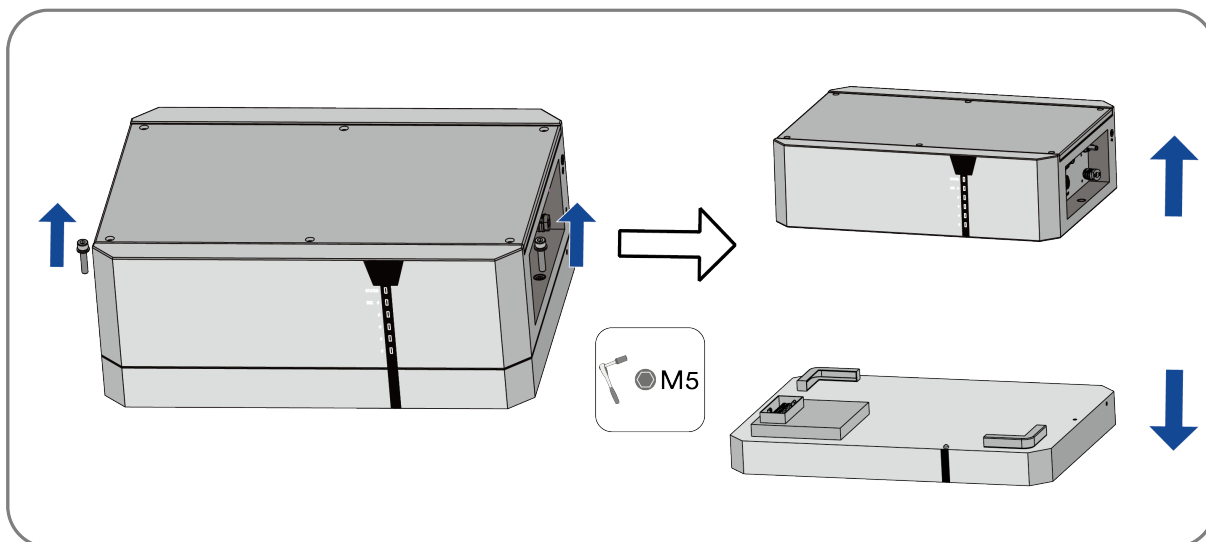
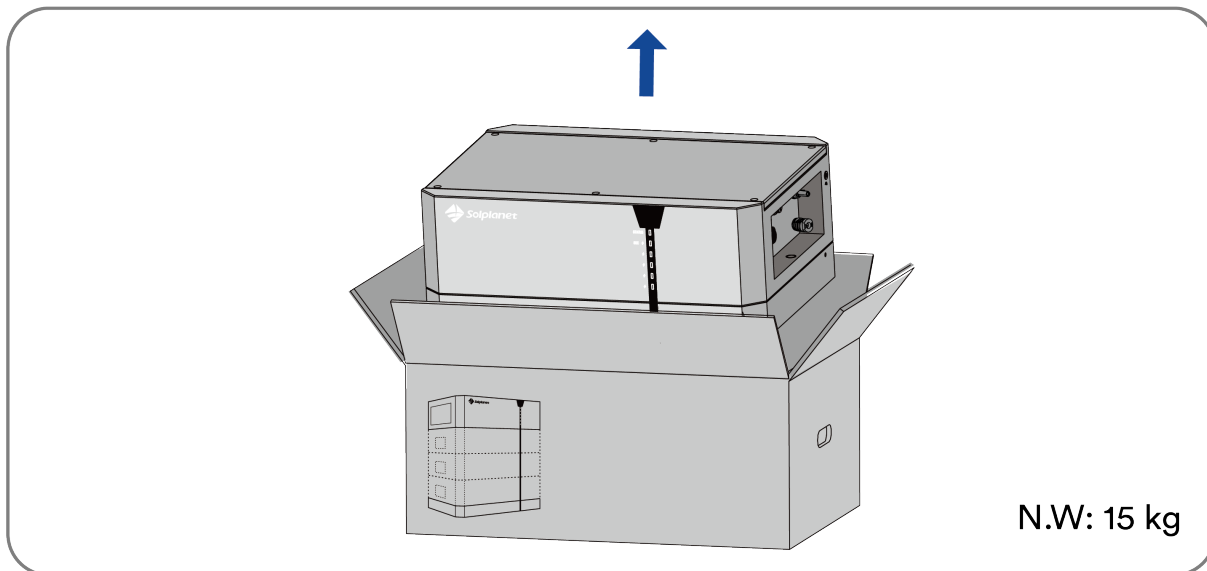

**Step 2:** Place the base along the wall, and ensure a distance of 40~50 mm between the wall and the base. Pay attention to the direction of the base. The power-mating connectors on the base should be on the outside.

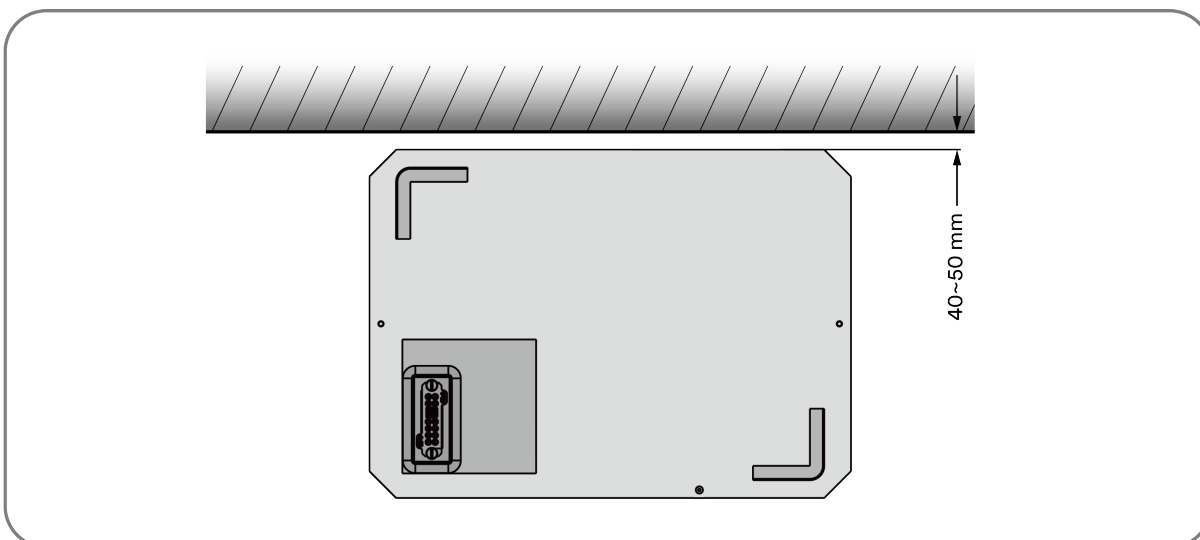

**Step 3:** Remove a battery module from the package. Place one battery module on the base and secure the battery module by the supplied screws(M5×25). Tightening torque: 4 Nm. Pay attention to the direction of the module. The power-mating connectors on the battery module and the base should be on the same side.

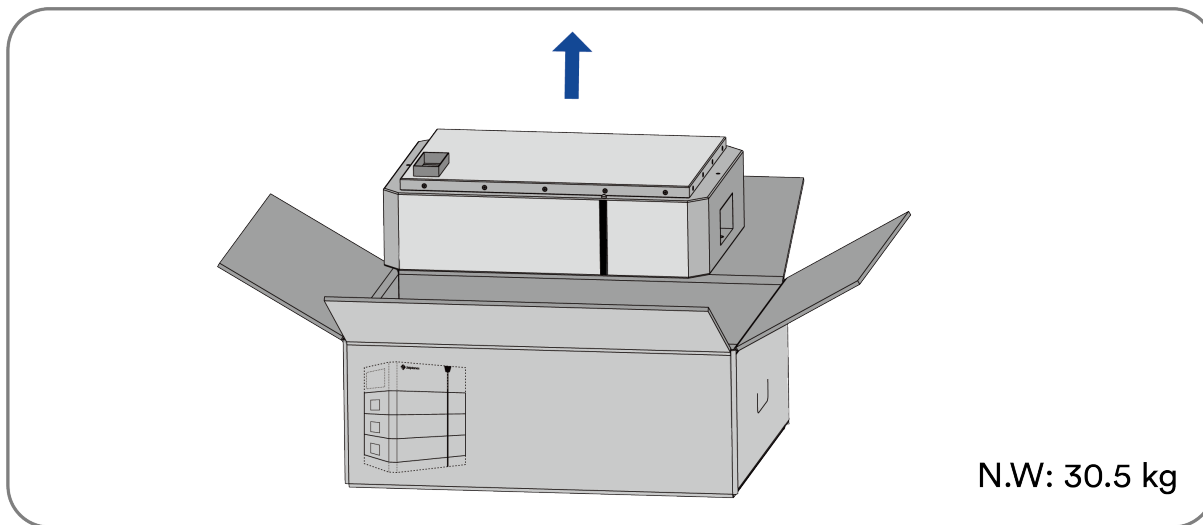

**Step 4:** Repeat the operations for the remaining battery modules.

**Step 5:** Place the BCU on top of the first battery module and secure the BCU by the supplied screws(M5×25). Tightening torque: 4 Nm. Pay attention to the direction of the BCU. The power-mating connectors on the battery module and the BCU should be on the same side.

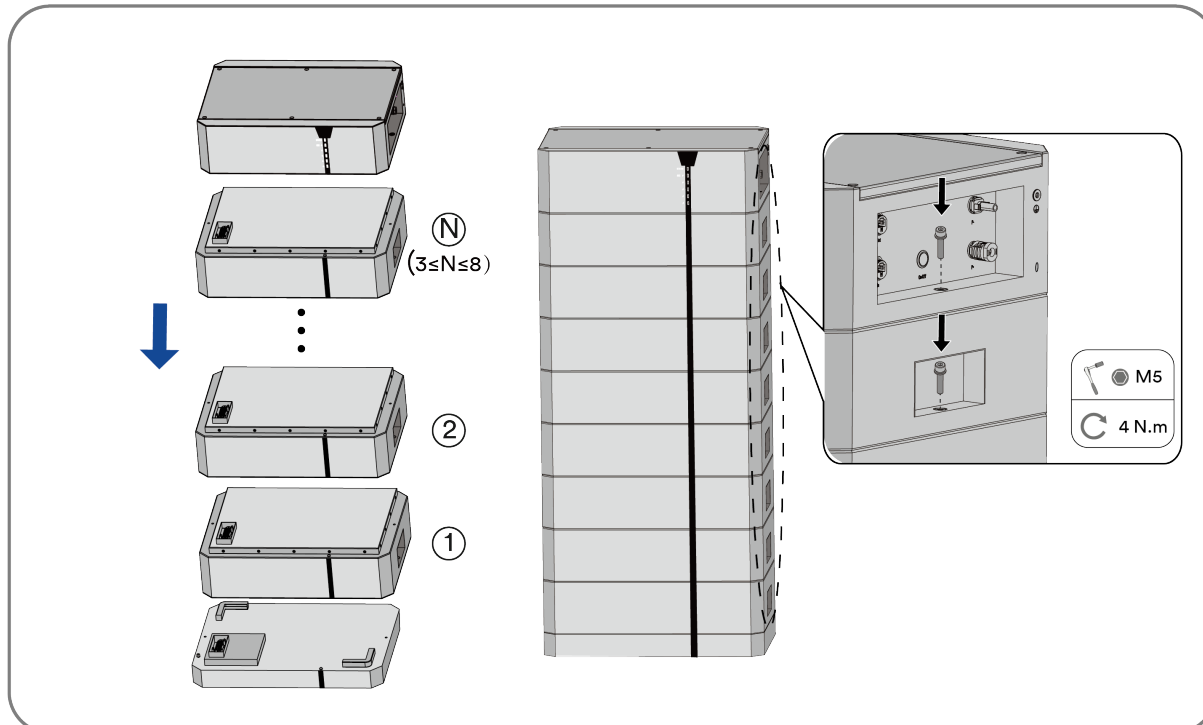

**Step 6:** Hold the L-bracket where it intends to be mounted on the wall and mark the position of the holes. Please pay attention that there may be power cables or other supply lines (e.g., gas or water) routed in the wall. Ensure that no cables or other supply lines are laid in the wall, which could be damaged when drilling holes.

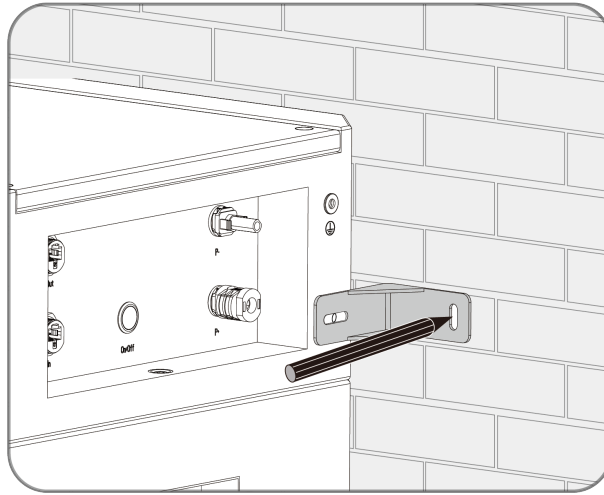

**CAUTION**

Damage to power cables and pipes can cause personal injury!

The walls may contain electrical cable or pipes (for example, gas or water).

- Ensure that power cable or pipes are not damaged when drilling.

**Step 7:** Set the L-bracket aside and drill the marked holes, at a diameter of 8 mm and a depth of 50 mm. Repeat on the other side of the BCU.

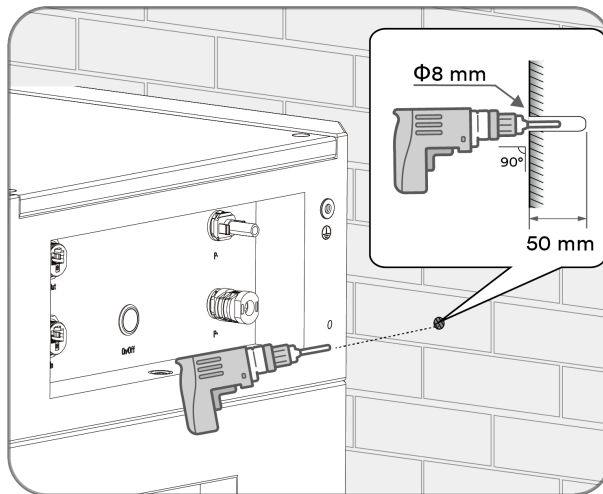

**Step 8:** Insert a screw anchor into the hole. Repeat on the other side of the BCU.

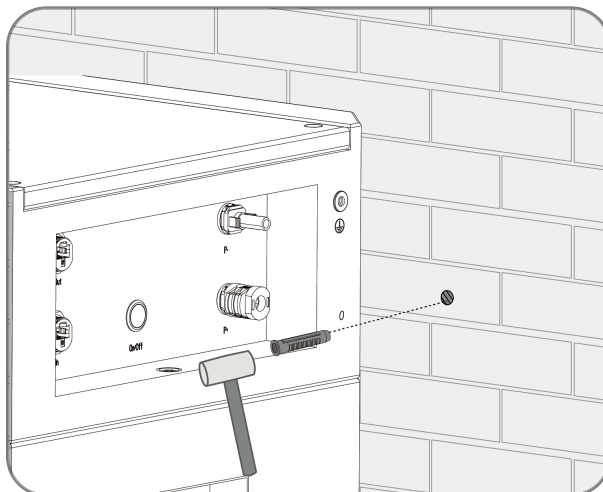

**Step 9:** Fix two L-brackets on both sides of the BCU with the supplied screws(M5×12), using a Ratchet wrench (4mm) to tighten it (torque: 4 Nm).

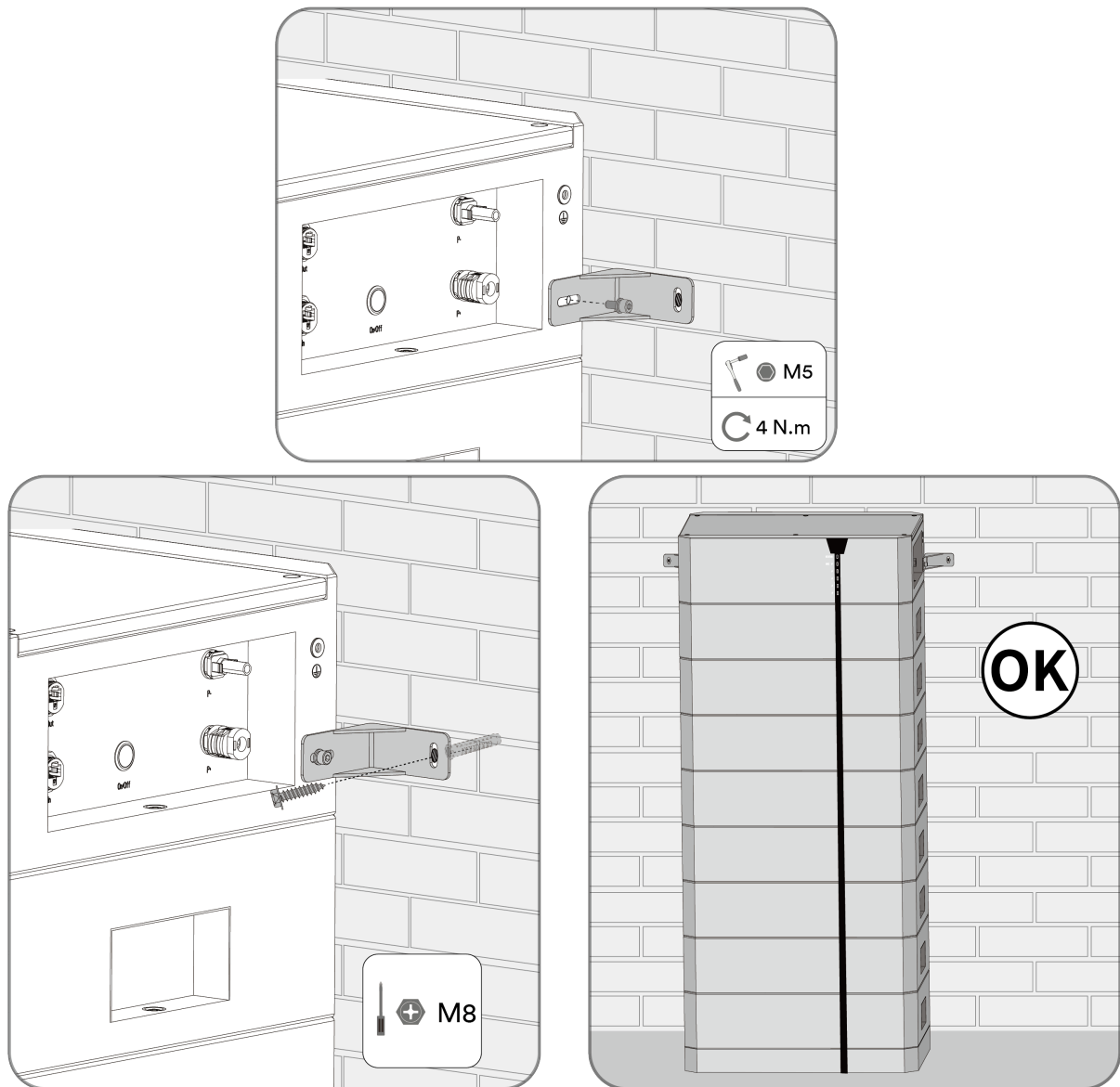

**Step 10:** Secure the hanger using screws(M8×40).

**Complete the installation.**

## 6 Electrical connection

### 6.1 Overview of the connection area

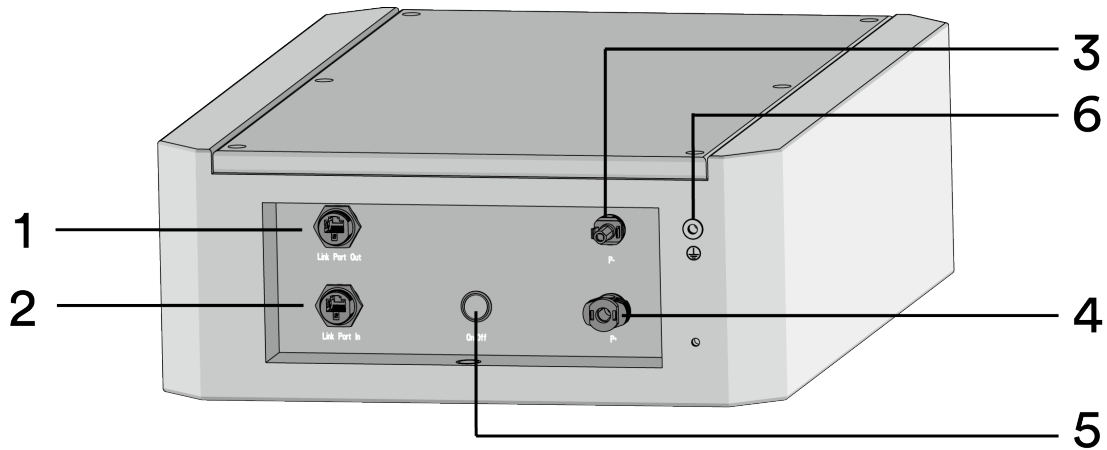

Figure shown here is for reference only. The actual product received may differ!

Object	Description
1	Link Port Out
2	Link Port In
3	P- (negative battery power output)
4	P+ (positive battery power output)
5	On/Off Button
6	Grounding Terminal

### 6.2 Connecting the grounding conductor

Additional material required (not included in the scope of delivery):

#### Requirements for the secondary protection ground cable:

Object	Description
1	Terminal SC10-6 or OT10-6 or DT10-6
2	Grounding cable cross-section: 10mm <sup>2</sup> copper
3	Heat shrink tubing

#### Procedure:

**Step 1:** Ensure the circuit breaker of the BCU is off.

**Step 2:** Strip the grounding cable to the length (L) which is approximately 2-3 mm longer than the crimping area of the ring terminal (E).

**Step 3:** Slide the heat shrink tubing over the cable.

**Step 4:** Crimp the cable onto the ring terminal with appropriate crimping pliers.

**Step 5:** Slide the heat shrink tubing to cover both the cable and the crimped section of the ring terminal.

**Step 6:** Use a heat gun to shrink the heat shrink tubing onto the cable and the ring terminal.

**Step 7:** Fix the grounding terminal by the screw(M6×16) with a phillips-screwdriver and tighten (torque: 6 Nm).

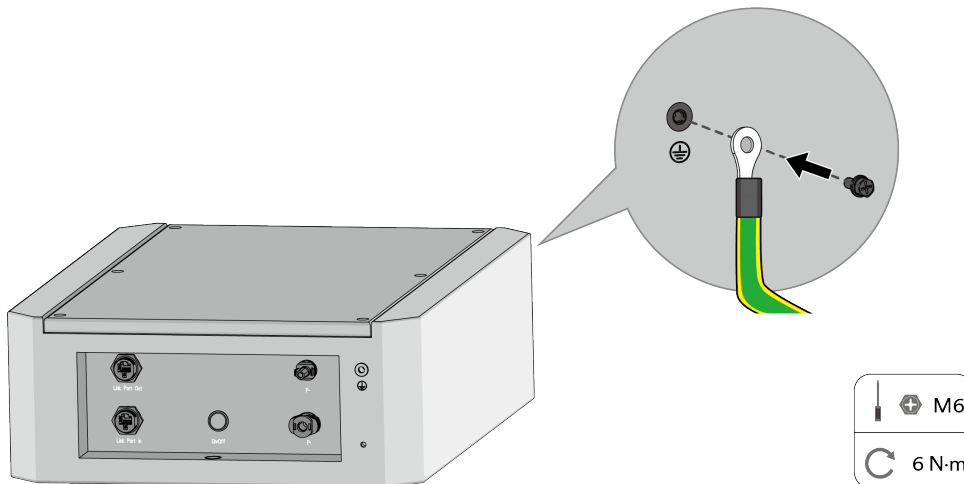
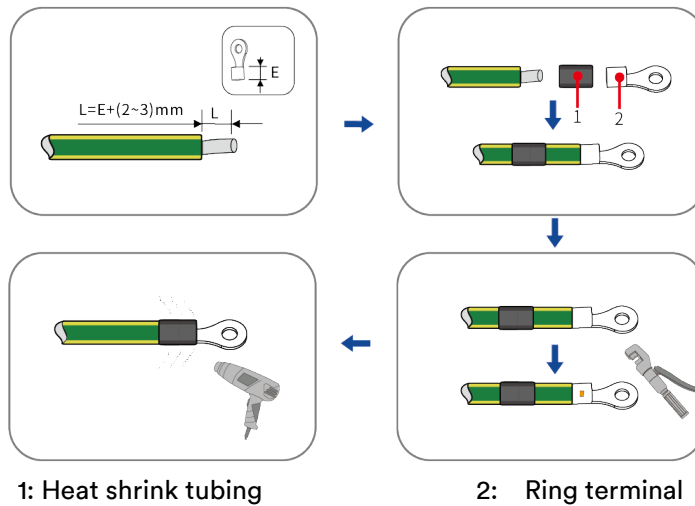

**Complete the installation.**

## 6.3 Connecting the power cable and network cable

**Additional material required (not included in the scope of delivery)**

- One network cable(Cat5, Cat5e or higher), see below for the minimum requirements.

**Network cable requirements:**

- Cable category: Cat5, Cat5e or higher
- Connector type: Metal shielded RJ45 of Cat5, Cat5e or higher

- Shielding: Yes
- UV-resistant for outdoor use
- Straight-through wired cabled
- Maximum cable length: 20 m

Do not use a "CROSSOVER" cable.

**Step 1:** Connect the supplied power cables to the DC connectors on the BCU. (P+ cable connect to the P+ terminal and P- cable connect to the P- terminal).

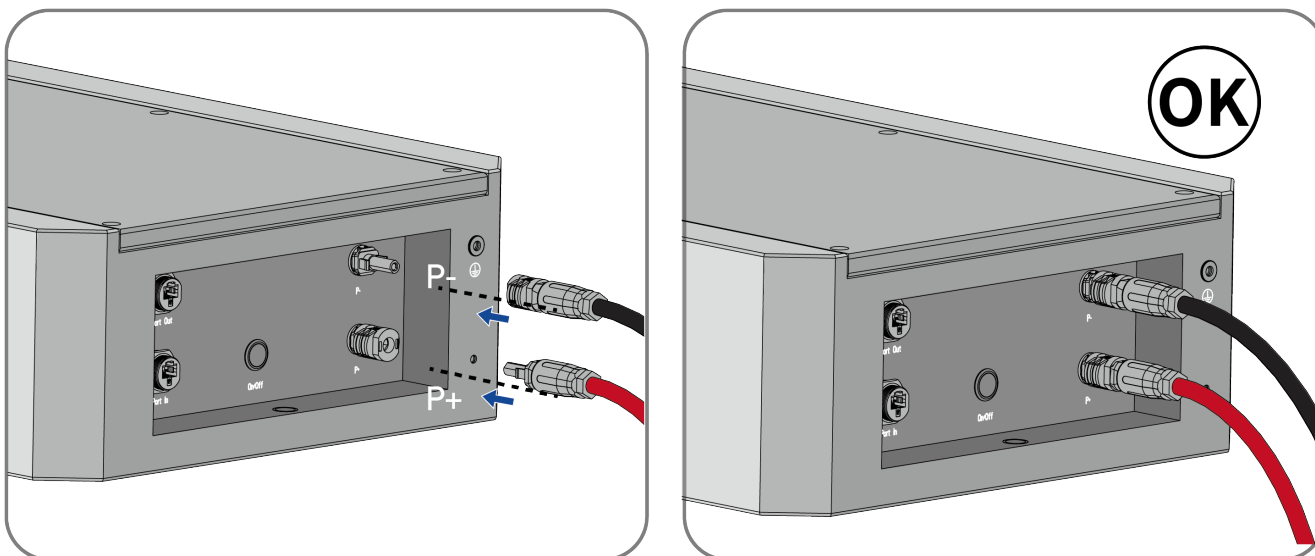

**Step 2:** Add the connector from the inverter package to the opposite ends of the power cables and connect them to the inverter battery input connectors.

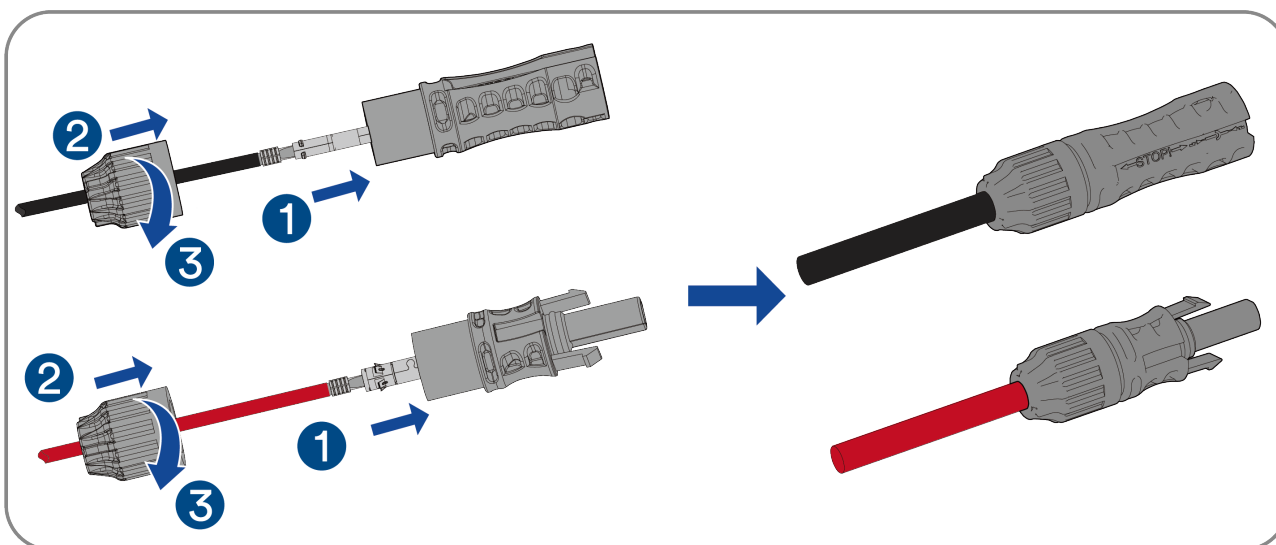

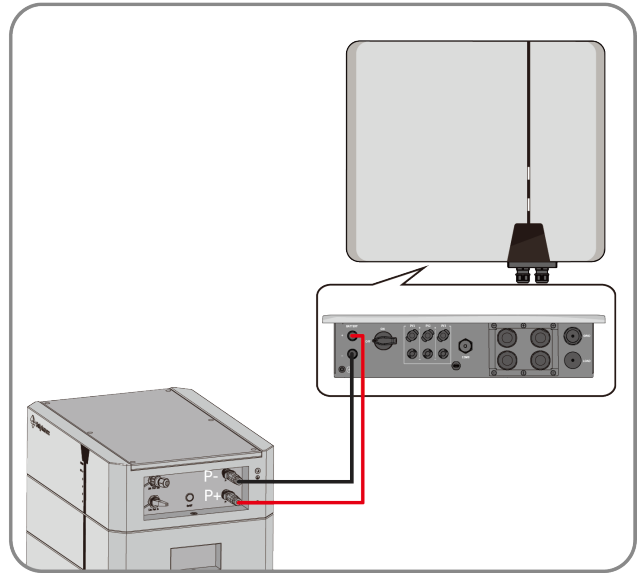
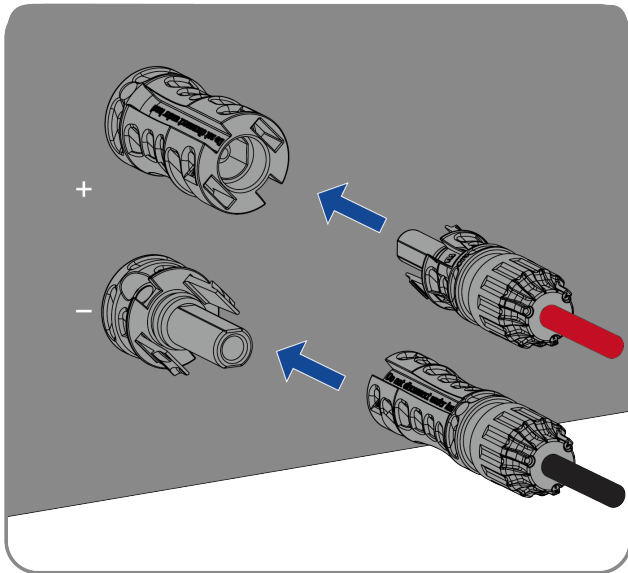

**Step 3:** Split the connectors. Lead the network cable through cable gland, and insert into the insulator until it snaps into place.

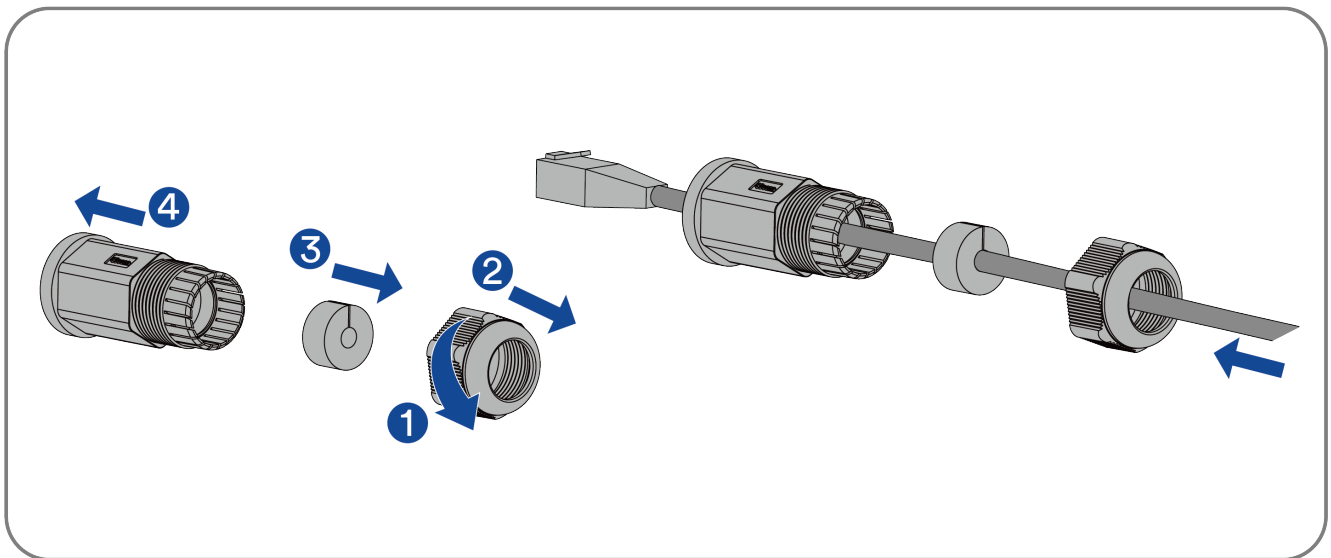

**Step 4:** Connect the “Link Port In” of the BCU to the BMS port of the inverter using a shielded CAT 5 (or higher) ethernet cable. Tighten the cable gland and the insulator.

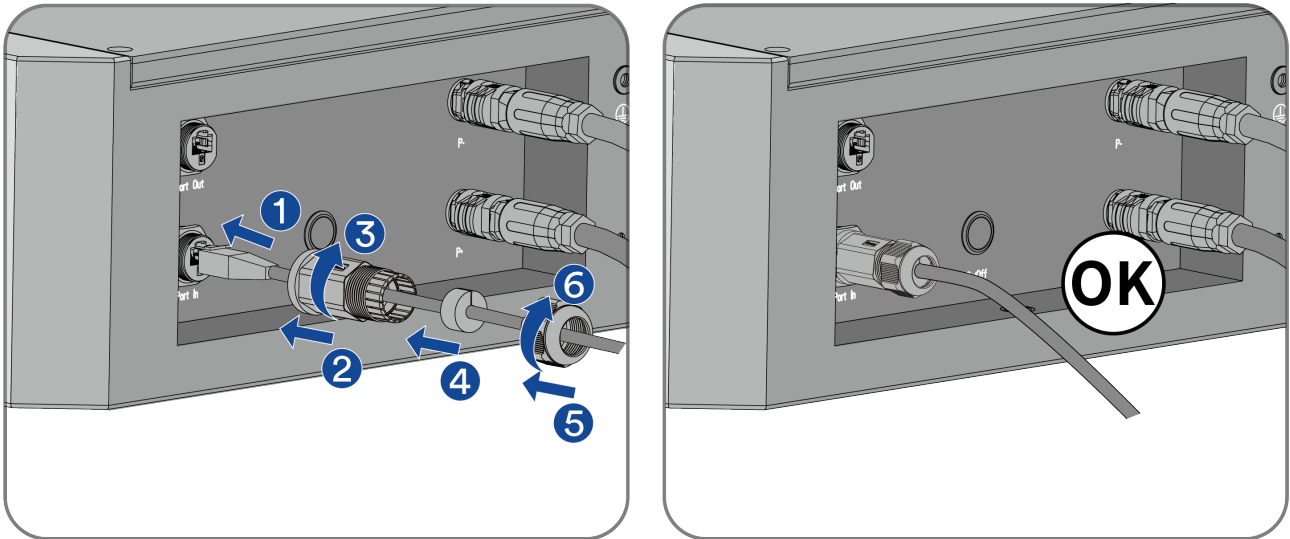

**Step 5:** Connect the terminating resistor to the “Link Port Out” of the BCU.

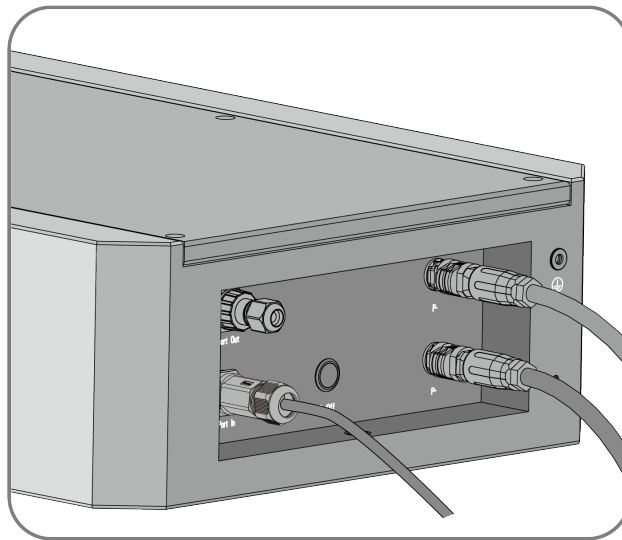

If multiple BCU's, therefore multiplied BESS's, are to be connected in parallel, then connect as follows:

- Connect the “Link Port Out” of the first BCU to the “Link Port In” of the adjacent BCU (daisy chain).
- Install the terminating resistor to the “Link Port Out” of the last BCU in the daisy chain.

## 6.4 Parallel system connection diagram

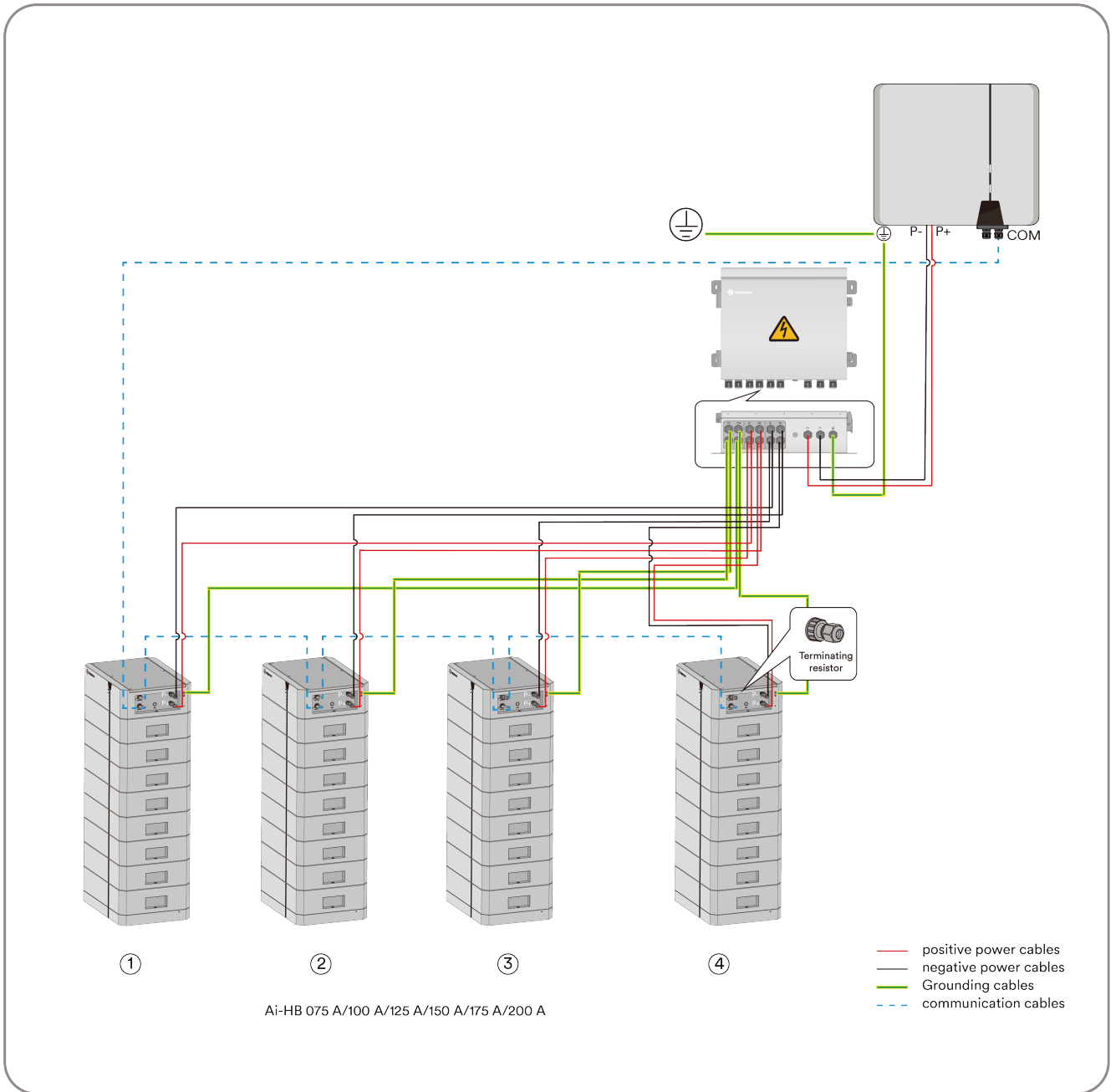

## NOTICE

Damage to the battery due to not configuring the system as required!

Configure the system according to the requirements, otherwise it may affect the performance of the battery system or damage it.

- The length of the power cables from the battery to the combiner box should be same.
- The number of modules for each stacked battery in a parallel system must be the same.
- The total power cable length between each battery and the inverter should be less than 20 meters.
- Recommend using the combine box ASW1000-CB-HB from solplanet.
- If the combiner box ASW1000-CB-HB is not used, the parallel connection device should meet the following requirements.
  - a) No less than IP55 for the outdoor use.
  - b) Maximum Operating Voltage:1000V DC.
  - c) Maximum Input Current for each battery string :30A DC.
  - d) Maximum Output Current: 60A DC.
  - e) Breaking Current:60A DC.

## 7 Commissioning and operating

### 7.1 Inspection before commissioning

Check the following items before commissioning the BESS:

- Ensure inverter is compatible with the battery.
- Ensure the inverter is correctly mounted as per Solplanet's guidelines, please refer to the inverter manual
- Ensure the battery is properly installed and secured in accordance with this manual.
- Ensure the circuit breaker between the battery system and the inverter is off.
- Ensure the communication cables and DC cables are correctly and securely connected.
- Ensure the ground terminal on the BESS is grounded.
- Ensure the DC power cables have been installed with the correct polarity.

### 7.2 Commissioning procedure

If all of the items mentioned above have been met then proceed as follows to commission and start-up the battery for the first time:

**Step 1:** Turn the circuit breaker on the BCU to the "ON" position.

**Step 2:** Wait for the status LED to turn yellow, and press the ON/OFF button for 5s, and the BESS will enter into working mode.

**Step 3:** Check whether the battery indicator of the inverter is on.

**Step 4:** Start inverter according to inverter start-up procedure.

**Step 5:** Commission the inverter according to the inverter commissioning procedure using the Solplanet App.

**Step 6:** Read the battery status information using the Solplanet App and confirm that the BESS is communicating with the inverter, observe the LED's on the BESS to determine the current status.



Recommended standard charging and discharging procedure as follow:

- Charging at a constant current with 0.5C until the SOC reach to 80%, and then charging to 100% SOC with 0.25C at 25°C.
- Discharging at a constant current with 0.6C until the SOC reach to 0% at 25°C.

## 8 Decommissioning the product

### **CAUTION**

Risk of injury due to weight of the battery module!

Injuries may result if the battery module is lifted incorrectly or dropped while being transported or installed.

- Transport and lift the battery module carefully. Take the weight of the battery module into account.
- Wear suitable personal protective equipment for all work on the battery system.

### **DANGER**

Danger to life from electric shock due to live DC cables or conductors at the battery system!

The DC cables connected to the battery system may be live. Touching the DC conductors or the live components leads to lethal electric shocks..

- Do not touch non-insulated cable ends.

#### **Procedure:**

**Step 1:** Switch off the inverter by first turning off the AC circuit breaker downstream of the AC output of the inverter and second by turning off the inverter DC switch.

**Step 2:** Switch off the BESS.

**Step 3:** Switch off the any external DC switches between the inverter and the BESS if there are any.

**Step 4:** Take off the nuts on the cable glands on the BESS operating panel.

**Step 5:** Remove all cables from the BESS.

**Step 6:** Loosen the screws on L-brackets between the BCU and the wall and remove the L-brackets.

**Step 7:** Loosen the screws between BCU and the battery modules and base.



Before lifting the battery module, ensure that the screws on both sides of them are removed.

**Step 8:** Tighten the nuts on the cable glands on the operating panel.

**Step 9:** Remove the BCU from the battery modules and then the battery modules from the base.

If the battery system is to be stored or shipped, pack the system using the original packaging or packaging that is suitable for the weight and dimensions of the system.

Dispose of the battery system in accordance with the locally applicable battery disposal regulations.

## 9 Technical data

Technical Specification						
Model	Ai-HB 075 A	Ai-HB 100 A	Ai-HB 125 A	Ai-HB 150 A	Ai-HB 175 A	Ai-HB 200 A
Module quantity	3	4	5	6	7	8
Nominal Energy* <sup>1</sup>	7.68 kWh	10.24 kWh	12.8 kWh	15.36 kWh	17.92 kWh	20.48 kWh
Nominal Voltage	153.6 V	204.8 V	256 V	307.2 V	358.4 V	409.6 V
Operating Voltage	120 V ~ 175.2 V	160 V ~ 233.6 V	120 V ~ 292 V	120 V ~ 350.4 V	120 V ~ 408.8 V	120 V ~ 467.2 V
Dimension (W*D*H)	540*390 *600 mm	540*390 *730 mm	540*390 *860 mm	540*390 *990 mm	540*390 *1120 mm	540*390 *1250 mm
Battery weight	106.5 kg	137 kg	167.5 kg	198 kg	228.5 kg	259 kg
Battery module weight	30.5 kg					
Max. Continuous charging current	25 A					
Max. Continuous discharging current	30 A					
Communication	CAN					
Operating temperature	Charge: 0 ~ 50°C Discharge: -20°C ~ 50°C					
Ingress protection rating	IP65					
Display	SOC and status indicator, LED indicator					
Installation	Indoor/Outdoor					
Max. Operating altitude	3000 m					
Relative humidity	5%~95% no condensing					
Cooling	Natural convection					
Cell type	Lithium-iron phosphate (LiFePO <sub>4</sub> )					
Life cycle	6000 times* <sup>2</sup>					
Standard and Certification	Safety	IEC62619, IEC62040-1, IEC62477-1				
	EMC	IEC61000-6-1, IEC61000-6-3, IEC61000-6-2, IEC61000-6-4				
	Transportation	UN38.3				

\*1. Nominal energy is defined under the following conditions: cell voltage 2.5~3.65V, 0.5C charge & discharge at +25°C.

\*2. Life cycle is defined under the following condition: 70%DOD, 0.5C charge & discharge at +25°C.

## 10 Troubleshooting

When the yellow LED indicator blinks, it indicates that the battery is in an alarm state. Different blink patterns indicate different alarm faults.

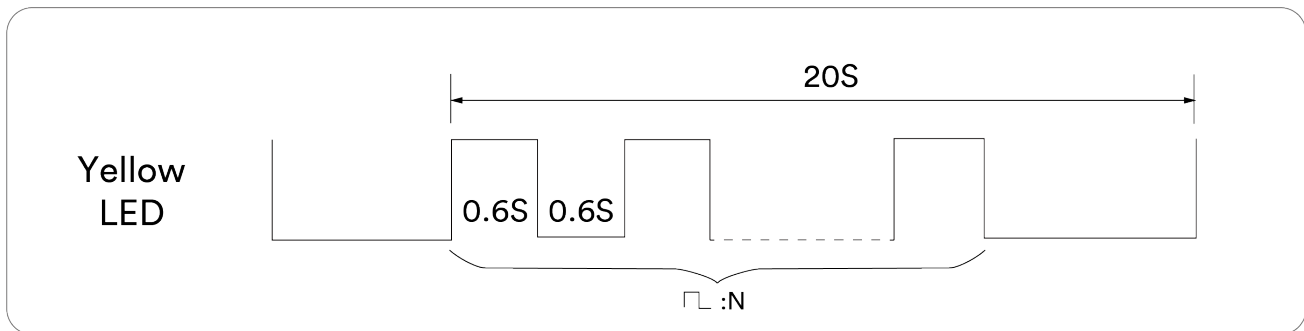

Number of yellow blinks: N	Warning Fault	Corrective measures
2	High cell voltage	Stop charging
3	Low cell voltage	Stop discharging
4	High temperature during charging	Stop charging and wait 30 minutes
	High temperature during discharging	Stop discharging and wait 30 minutes
5	Low temperature during charging	Wait for the temperature of the cell to rise before charging
	Low temperature during discharging	Wait for the temperature of the cell to rise before discharging
6	Over current during charging	Waiting 60s to recovery, or restart the inverter
	Over current during discharging	Waiting 60s to recovery, or restart the inverter
7	Low system insulation	Check insulation
8	High system voltage	Stop charging
9	Low system voltage	Stop discharging
10	High temperature of the BCU	Stop charging and discharging, and wait 30 minutes

If the red indicator is constant, the battery is faulty. Turn off the circuit breaker immediately and contact the manufacturer for after-sales service.

# 11 Maintenance

## Cleaning

It is recommended that the battery system be cleaned periodically. If the enclosure is dirty, please use a soft, dry brush or a dust collector. Liquids such as solvents, abrasives, or corrosive liquids should not be used to clean the enclosure.

## Maintenance

The battery module should be stored in an environment with a temperature range between  $-20^{\circ}\text{C}$  ~  $+45^{\circ}\text{C}$ , and charged regularly according to the table below with no more than 0.5C to the SOC of 30% after a long time of storage.

Temperature	Relative humidity	Storage time	Original SOC
Below $-20^{\circ}\text{C}$	/	Not allowed	/
$0\sim 25^{\circ}\text{C}$	35%~85%	$\leq 6$ months	$25\% \leq \text{SOC} \leq 50\%$
$-20\sim 45^{\circ}\text{C}$	35%~85%	$\leq 1$ months	$25\% \leq \text{SOC} \leq 50\%$
Above $45^{\circ}\text{C}$	/	Not allowed	/

## NOTICE

Damage to the system due to under voltage!

- Charge the over-discharged system within seven days when the temperature is above  $25^{\circ}\text{C}$ .
- Charge the over-discharged system within fifteen days when the temperature is below  $25^{\circ}\text{C}$ .

## 12 Recycling and disposal

Dispose of the packaging and replaced parts according to the rules applicable in the country where the device is installed.



Do not dispose of the product together with the household waste but in accordance with the disposal regulations for electronic waste applicable at the installation site.

## 13 EU declaration of conformity

Within the scope of the EU directives:

-Electromagnetic compatibility directive 2014/30/EU

(L 96/79-106, March 29, 2014)(EMC)

-Low voltage directive 2014/35/EU (L 96/357-374, March 29, 2014)(LVD)

Restriction of the use of certain hazardous substances 2011/65/EU

(L 174/88, June 8, 2011) and 2015/863/EU (L 137/10, March 31, 2015) (RoHS)

AISWEI New Energy Technology (Yangzhong) Co., Ltd. confirms herewith that the products described in this document are in compliance with the fundamental requirements and other relevant provisions of the above mentioned directives.

The entire EU Declaration of Conformity can be found at [www.solplanet.net](http://www.solplanet.net).



## 14 Service and warranty

If you have any technical problems concerning our products, please contact Solplanet service.

We require the following information in order to provide you with the necessary assistance:

- Battery serial numbers
- Battery type and model
- Inverter device type
- Inverter serial number
- Type and number of connected PV modules
- Mounting location
- Installation date

Warranty terms and conditions can be downloaded at [www.solplanet.net](http://www.solplanet.net).

When the customer needs warranty service during the warranty period, the customer must provide a copy of the invoice, factory warranty card, and ensure the electrical label of the inverter is legible. If these conditions are not met, Solplanet has the right to refuse to provide with the relevant warranty service.

## 15 Contact

### EMEA

Service email: [service.EMEA@solplanet.net](mailto:service.EMEA@solplanet.net)

### APAC

Service email: [service.APAC@solplanet.net](mailto:service.APAC@solplanet.net)

### LATAM

Service email: [service.LATAM@solplanet.net](mailto:service.LATAM@solplanet.net)

### AISWEI Pty Ltd.

Hotline: +61 390 988 674

Add.: Level 40, 140 William Street, Melbourne VIC 3000, Australia

### AISWEI B.V.

Hotline: +31 208 004 844 (Netherlands)

+48 134 926 109 (Poland)

Add.: Barbara Strozziilaan 101, 5e etage, kantoornummer 5.12, 1083HN Amsterdam, the Netherlands

### AISWEI Technology Co., Ltd

Hotline: +86 400 801 9996

Add.: Room 904 - 905, No. 757 Mengzi Road, Huangpu District, Shanghai 200023





AISWEI Technology Co., Ltd.

Zur Verfügung gestellt von: [www.photovoltaiishop.eu](http://www.photovoltaiishop.eu)